



Throttle Type	Free Speed (RPM)			Terminations					
	12,000	13,500	14,500	3" Type 1 Cut-Off Wheel	4" Type 1 Cut-Off Wheel	300 Collet	Universal Collet (short)	3" DCW Wheel	4" DCW Wheel
Latching	12L2277	12L2276	12L2278	-27	-28	-36 *	-45 **	-83	-84
Lock-Off	12S2277	12S2276	12S2278	-27	-28	-36 *	-45 **	-83	-84

* NOTE: Optional Collets for Termination -36 (300 Series Collet)

Model number example: 12L2278-3608 (equipped with a 1/8" 300 series collet)

08 = 1/8" **20** = 5/16"
10 = 5/32" **22** = 11/32"
12 = 3/16" **24** = 3/8"
14 = 7/32" **M6** = 6mm
18 = 9/32" **M8** = 8mm

** NOTE: Optional Collets for Termination -45 (Universal Collet)

Model number example: 12L2278-4508 (equipped with a 1/8" short Universal collet)

08 = 1/8"
M3 = 3mm
M6 = 6mm

For additional product information visit our website at:

<https://dotcotool.com/product-category/dotco-air-tools/dotco-sanders/dotco-right-angle-sanders/dotco-12-22-series-right-angle-sanders/>

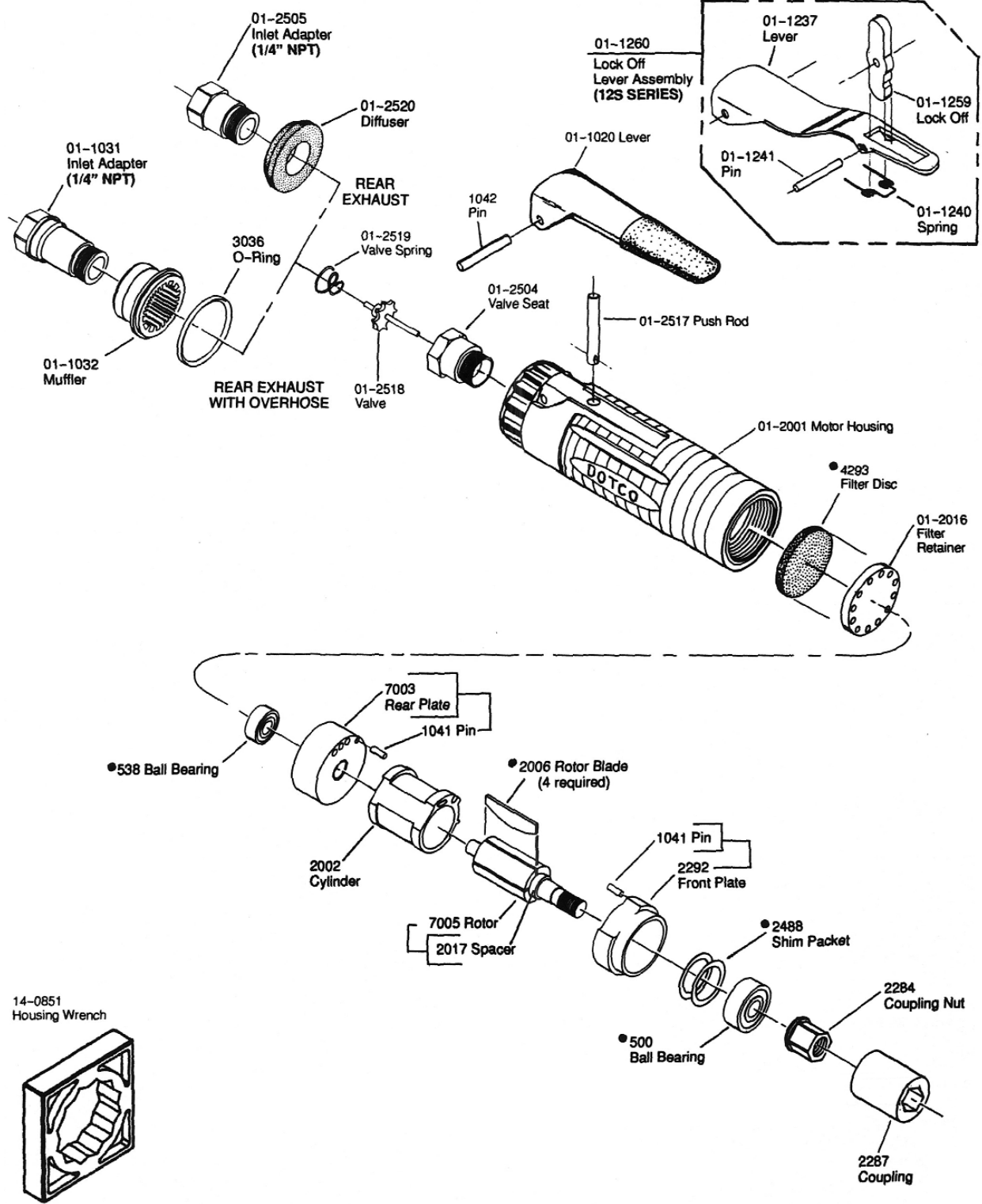

14-0851 Housing Wrench

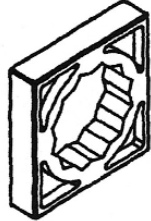

(*) Indicates recommended spare part.
 Order one (1) or one set for every 6-10 tools.
 Small, low cost or easily lost parts should also
 be ordered on the basis of 3-4 per 10 tools.

DOTCO 12-22 Series Low Profile Grinders & Sanders

PL30-550
August 24, 2001

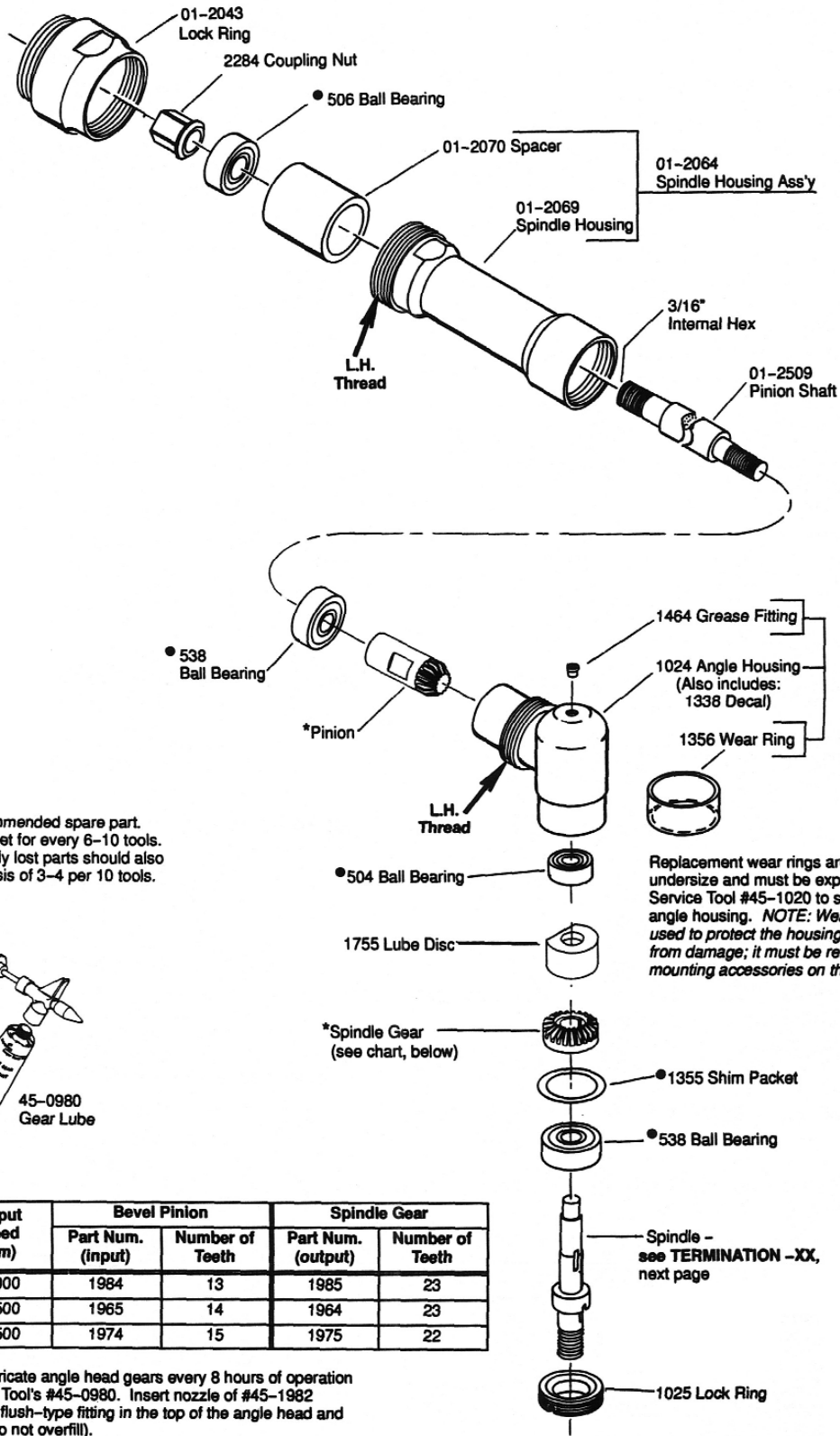

(●) Indicates recommended spare part. Order one (1) or one set for every 6-10 tools. Small, low cost or easily lost parts should also be ordered on the basis of 3-4 per 10 tools.

45-1982 Grease Gun



45-0980 Gear Lube

Replacement wear rings are 0.050" undersize and must be expanded using Service Tool #45-1020 to slip onto the angle housing. *NOTE: Wear Ring is used to protect the housing diameter from damage; it must be removed for mounting accessories on the housing.*

(*)

Tool Series	Output Speed (rpm)	Bevel Pinion		Spindle Gear	
		Part Num. (input)	Number of Teeth	Part Num. (output)	Number of Teeth
12-2777	12,000	1984	13	1985	23
12-2776	13,500	1965	14	1964	23
12-2778	14,500	1974	15	1975	22

LUBRICATION: Lubricate angle head gears every 8 hours of operation using Cooper Power Tool's #45-0980. Insert nozzle of #45-1982 Grease Gun into the flush-type fitting in the top of the angle head and pump 4 to 5 times (do not overfill). The air motor should be lubricated with a high grade spindle oil such as SAE # 5, or use #45-0918; two or three drops per minute is sufficient.

TERMINATION 27
 3" Type 1 Cut-Off Wheels
 3" x 3/16" x 3/8"

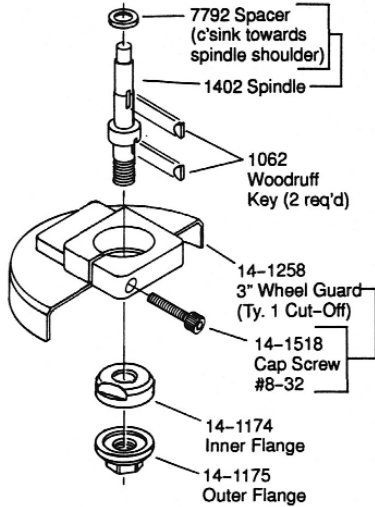

Includes:
 14-0186 (3/16") Hex Wrench
 14-0809 (9/16") Wrench
 14-0812 (3/4") Wrench

TERMINATION 28
 4" Type 1 Cut-Off Wheels
 4" x 3/16" x 3/8"

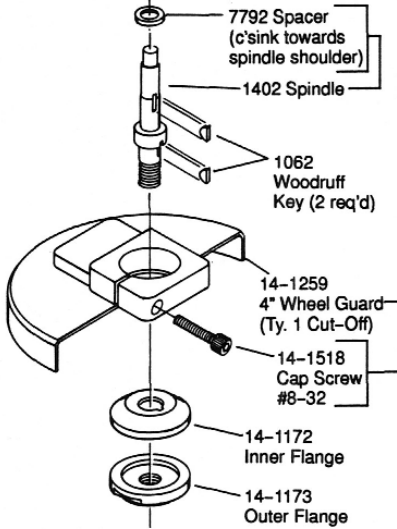

Includes:
 14-0186 (3/16") Hex Wrench
 14-0820 (1-1/4") Wrench

TERMINATION 36

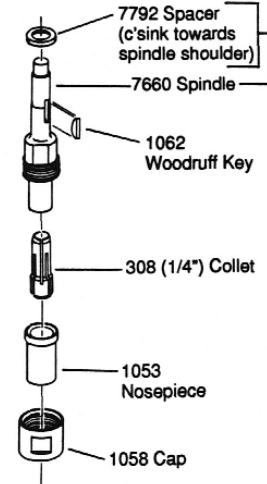

Includes:
 14-0807 7/16" Wrench
 14-0811 11/16" Wrench

TERMINATION 45
 Short Collet

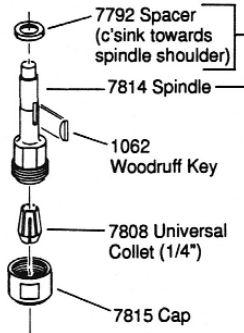

Includes:
 14-0807 (7/16") Wrench
 14-0811 (11/16") Wrench

TERMINATION 83
 3" Depressed Center Wheels
 3" x 1/4" x 3/8"

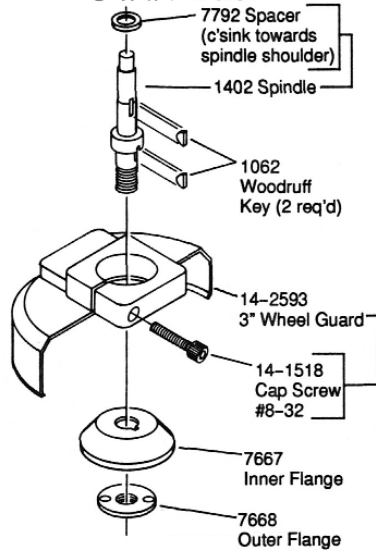

Includes:
 14-0186 (3/16") Hex Wrench
 7666 Spanner

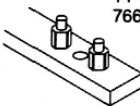

TERMINATION 84
 4" Depressed Center Wheels
 4" x 1/4" x 3/8"

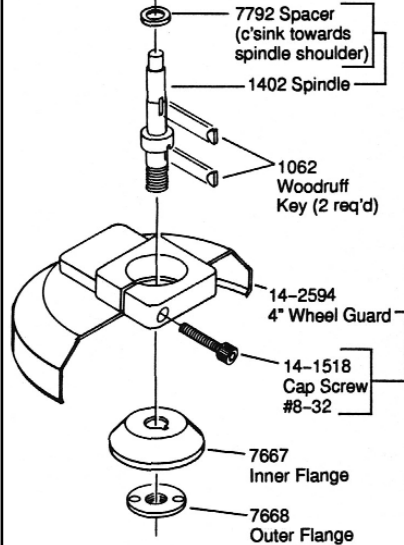

Includes:
 14-0186 (3/16") Hex Wrench
 7666 Spanner

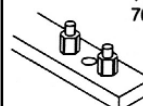

Service Instructions

DISASSEMBLY INSTRUCTIONS:

To Disassemble Complete Sander

1.) Place the special 12-point socket wrench, part #14-0851, horizontally in a vise and insert the tool's housing vertically into the wrench. Unscrew Lock Ring part #01-2043 and remove the angle head assembly from the tool. At the same time, remove Spacer, part #01-2070, from the rear of the angle head extension.

To remove & disassemble motor:

2.) Once the angle head assembly has been removed, pull motor from housing. Hold motor in one hand and tap the rear of rotor, part # 7005, with a brass drive punch until Rear Plate, part #7003, and Ball Bearing, part #538, are free from rotor. Remove Cylinder, part #2002 and four Rotor Blades, part #2006. Coupling Nut, part #2284, may be removed by holding the rotor in soft vise jaws and unthreading the coupling nut. The Front Plate, part #2292, and Ball Bearing, part #500 can now be pressed off. NOTE: Do Not Loose Spacer, part #2017.

Removing spindle housing from angle:

3.) **CAUTION!** Lightly hold the Angle Head Housing, part #1024, in soft vise jaws (BE CAREFUL NOT TO CRUSH) and remove spindle housing assembly with wrench on flats at rear of spindle housing. NOTE: Left Hand Thread

4.) Using a 3/16" hex wrench in rear of Pinion Shaft, part #01-2509, and an open end wrench on Coupling Nut, part #22284, remove coupling nut. Push rear end of Pinion Shaft, part #01-2509, to disassemble from spindle housing. Now, clamp Pinion Shaft in soft vise jaws and remove pinion and Ball Bearing, part #538.

To disassemble angle head:

5.) Remove Lock Ring, part #1025, and pull out the spindle assembly. Remove ball Bearing, part #504, and press off Spindle Gear. After Key is removed, Ball Bearing, part #538, can be pressed off spindle.

ASSEMBLY INSTRUCTIONS

All parts should be thoroughly cleaned and inspected before assembly. Ball bearings are normally replaced in most repairs.

To Assemble Motor

6.) Make sure all parts are clean and oiled. Press Pins, part #1041, if necessary, into motor end plates. To correct for bearing tolerances, it is necessary to use shims to maintain correct clearances between end of the rotor and the bearing plates. Shim Packet, part #2488, contains a 0.0001" shim and two 0.002" shims. Insert a .002" shim in the Front Bearing Plate's pocket and install #500 Ball Bearing into the Front Plate. Also install #538 Ball Bearing into the Rear Bearing Plate, #7003. Slip Spacer, part #2017, onto the threaded end of the Rotor. Support the rotor on the rear end and assemble the front plate assembly onto the rotor by pressing on the bearing's inner race. Thread Driver, part #2284, onto rotor tightly by holding rotor in soft vise jaws.

7.) Hold rotor in left hand and front bearing plate in the other hand. Apply an outward (pulling) pressure and observe the spacing between the end of the rotor and bearing plate. This must be from flush, not rubbing to 0.002" maximum. If the rotor rubs the bearing plate, reduce the spacing between the bearing and bearing plate by removing the 0.002" shim entirely or by substituting the 0.001" shim for the 0.002" shim. However, if there was more than .002" between the bearing and the bearing plate, add 0.001" between the bearing and bearing plate. Install Cylinder, part #2002, NOTE: Be sure cylinder is not backwards, air inlet in cylinder must line up with air inlet in Rear Plate, part #7003, when Pin, part #1041, is engaged in mating slot of cylinder.

8.) Insert all four Rotor Blades, part #2006, in rotor. Support the assembly on the face of the Driver, part #2284. Press on the Rear Plate, Part #7003, by pressing on the inner race of Ball Bearing, part #538, just enough to bring the bearing plate up against the cylinder. There should be only a slight drag between the bearing

plate and the cylinder when these are moved in the fingers. Position the cylinder until motor turns freely.

9.) Insert the motor assembly into housing. Screw in Lock Ring, part #01-2043, but do not tighten at this time.

To Assemble Angle Head:

NOTE: Do not place grease in angle head assembly until the proper gear mesh is obtained. Refer to instructions below.

10.) Make certain all parts are properly cleansed. Press ball Bearing, part #538, against spindle shoulder; press only on bearing's inner race. Insert Key, part #1062, in slot of spindle. Align keyway of bevel gear with key and press gear into spindle until it seats on inner race of bearing. Complete the spindle assembly by pressing on Ball Bearing, part #504, until it seats on spindle shoulder.

NOTE: Lube discs are not installed until after gear mesh is obtained by proper shimming.

Insert this assembly into housing and thread Lock Ring, part #1025, into housing until tight.

Spindle Housing / Spindle Subassembly:

11.) To assemble the pinion assembly, press bearing, part #538, onto Pinion Shaft, part #01-2509, and thread on pinion. Hold pinion shaft in soft vise jaws and tighten pinion. Slide this assembly into Spindle Housing, part #01-2069, then, install Ball Bearing, part #2284, on rear end of pinion shaft. Hold pinion shaft with a 3/16" hex wrench and tighten Coupling Nut, part #2284, with an open end wrench. Thread this assembly onto angle housing, (**NOTE:** Left hand thread), making sure that the gear teeth of the pinion mesh with the gear by revolving the spindle slowly. Tighten spindle housing.

Gear Mesh & Shimming:

12.) Pinion assembly and spindle assembly (without Lube Discs) should be in angle housing and hold in place with Lock Ring tightened, per above instructions. Gears must be shimmed at this time according to the following instructions.

When proper shimming is obtained, remove spindle assembly from the angle head, remove top Ball Bearing, part #504, and install Lube Disc, part #1755. Discs must be filled with CooperTools' Lube #45-0908 prior to assembly on the spindle. Reinstall spindle assembly into the housing aligning flats on lube disc with pinion gear and tighten lock ring.

13.) Due to gear manufacturing and bearing tolerances, it is sometimes necessary to place a thin shim between the outer race of Bearing, part #538, and the internal shoulder of angle housing, part #1024, against which it seats. There should be a backlash of 0.002" - 0.003" between gears. After the angle head spindle and angle head pinion have been assembled and before any lubricant has been applied to the gears, slowly rotate the spindle back and forth a few times with fingers. If the gears are in mesh but no backlash can be felt, remove the spindle's Lock Ring, part #1025, remove spindle assembly and position two shims, each 0.001" thick (from shim packet, part #1355) on the outer race of Bearing, part #538. Use a little grease to hold shims on bearing. Reassemble components and again follow procedure. If there is still not sufficient backlash, add another shim. Shim Packet, part #1355, contains two 0.001" and one 0.002" thick shims. It is suggested that when a gear is worn out that both gears be replaced.

To Assemble Complete Angle Head Assembly To The Motor:

14.) Install Coupling, part #2287, over motor's Coupling Nut, part #2284, and thread the angle head assembly into the Lock Ring, part #01-2043. (**NOTE:** Left hand thread) Be sure that driver in angle head properly engages Coupling, part #2287. Before tightening, position the angle head assembly approximately in the desired position and hold both housings while tightening Lock Ring.

CAUTION: It is important that the Lock Ring remains tight.

DOTCO 12-22 Series Low Profile Grinders & Sanders

Safety First!

ALWAYS COMPLY WITH:

1. General industry Safety & Health Regulations, Part 1910, OSHA 2206, available from: Sup't of Documents; Government Printing Office; Washington, DC 20402.
2. Safety Code of Portable Air Tools, ANSI B186.1 available from: American National Standards Institute, Inc.; 1430 Broadway; New York, NY 10018.
3. State and Local regulations.

Portions of the above codes and regulations are listed below for quick reference.

THE FOLLOWING EXCERPTS ARE NOT INTENDED TO BE ALL INCLUSIVE: STUDY AND COMPLY WITH ALL REGULATIONS!

1. **TOOL INTENT:** Tools shall be used only for purposes intended in their design (refer to product catalog).
2. **AIR SUPPLY:** Test and operate tools at 90 PSIG maximum unless tool is marked otherwise. Use recommended airline filters-regulators-lubricators.
3. **UNUSUAL SOUND or VIBRATION:** If tool vibrates or produces an unusual sound, repair immediately for correction.
4. **OPERATOR PROTECTIVE EQUIPMENT:** Wear goggles or face shield at all times tool is in operation. Other protective clothing shall be worn, if necessary. SEE REGULATIONS.
5. **SAFETY MAINTENANCE PROGRAM:** Employ a safety program to provide inspection and maintenance of all phases of tool operation and air supply equipment in accordance with "Safety Code for Portable Air Tools."



CAUTION: Disconnect the air supply hose before servicing the tool.

INSTALLATION:

For best performance, a working air pressure of **90 pounds per square inch** is recommended. Piping, fittings, and hose should be adequate to maintain **90 psig** while the tool is in operation. An air line filter and lubricator, such as CooperTools' #F02-M Filter (1/4" NPT) and #L02-EP Lubricator (1/4" NPT) should be used (refer to product catalog). Hose should be blown out before attaching to tool.

LUBRICATION:

The gears in angle head style tools must be lubricated every 8 hours of operation with high quality gear grease. CooperTools' grease #45-0980 is recommended. A Grease Gun, #45-1982, is furnished with each geared tool. Insert the nozzle into the flush type lube fitting, located on the side or top of the angle head, and pump four or five times. The motor must be lubricated and moisture free. Use a high grade SAE #5 spindle oil, such as CooperTools' Lubricating oil #45-0918 (one quart). Two or three drops per minute should be sufficient lubrication. **NOTE: Turbine motor type tools (10-90 & 10-95) must NOT be oiled.**

LOSS OF POWER:

It is seldom necessary to disassemble this tool for loss of power. A loss of power may not be related to the tool. First, check the air line regulator. Also, check the air line pressure; it should be 90 psig at or near the tool while the tool is running. Check the size of hose and fittings to be certain they are not causing air restrictions. Make certain they are not plugged with dirt, rust, or scale.

SERVICE INSTRUCTIONS:

The parts of this tool are small and require careful handling. We recommend the tool be returned to the factory for repair. However, if the tool is to be repaired in the field, carefully follow instructions. Do not squeeze the tool or parts in a vise except as specified. Care must be used during assembly and disassembly. When pressing bearings onto a shaft, press only on the inner race. When pressing bearings into a bore, press on the outer race only. **NOTE: Ball bearings are the shielded type. They are lubricated for life by the bearing manufacturer and should not be washed out with solvents to clean.**



WARNING!

CHECK SPEED OF TOOL WITHOUT WHEEL BEFORE IT IS RELEASED FOR USE.

The **SPEED TOLERANCE** is rated speed minus 10%. The tool must **NOT** have a free speed higher than the RPM stamped on the housing. Use an accurate tachometer to check the tool speed, with 90 psig air pressure at the tool with the tool running.

Sales & Service Centers

Note: All locations may not service all products. Please contact the nearest Sales & Service Center for the appropriate facility to handle your service requirements.

Dallas, TX
**Apex Tool Group
Sales & Service Center**
1470 Post & Paddock
Grand Prairie, TX 75050
Tel: 972-641-9563
Fax: 972-641-9674

Detroit, MI
**Apex Tool Group
Sales & Service Center**
2630 Superior Court
Auburn Hills, MI 48326
Tel: 248-391-3700
Fax: 248-391-7824

Houston, TX
**Apex Tool Group
Sales & Service Center**
6550 West Sam Houston
Parkway North, Suite 200
Houston, TX 77041
Tel: 713-849-2364
Fax: 713-849-2047

Lexington, SC
Apex Tool Group
670 Industrial Drive
Lexington, SC 29072
Tel: 800-845-5629
Tel: 803-951-7544
Fax: 803-358-7681

Los Angeles, CA
**Apex Tool Group
Sales & Service Center**
15503 Blackburn Avenue
Norwalk, CA 90650
Tel: 562-623-4457
Fax: 562-802-1718

Seattle, WA
**Apex Tool Group
Sales & Service Center**
2865 152nd Avenue N.E.
Redmond, WA 98052
Tel: 425-497-0476
Fax: 425-497-0496

York, PA
**Apex Tool Group
Sales & Service Center**
3990 East Market Street
York, PA 17402
Tel: 717-755-2933
Fax: 717-757-5063

Canada
**Apex Tool Group
Sales & Service Center**
5925 McLaughlin Road
Mississauga, Ont. L5R 1B8
Canada
Tel: 905-501-4785
Fax: 905-501-4786

Germany
Cooper Power Tools
GmbH & Co. OHG
a company of
Apex Tool Group, LLC
Industriestraße 1
73463 Westhausen
Germany
Tel: +49 (0) 73 63 81 0
Fax: +49 (0) 73 63 81 222

England
Cooper Power Tools
GmbH & Co. OHG
a company of
Apex Tool Group, LLC
C/O Spline Gauges
Piccadilly, Tamworth
Staffordshire B78 2ER
United Kingdom
Tel: +44 1827 8741 28
Fax: +44 1827 8741 28

France
Cooper Power Tools SAS
a company of
Apex Tool Group, LLC
25 rue Maurice Chevalier
77330 Ozoir-La-Ferrière
France
Tel: +33 1 6443 2200
Fax: +33 1 6443 1717

China
Cooper (China) Co., Ltd.
a company of
Apex Tool Group, LLC
955 Sheng Li Road,
Heqing Pudong, Shanghai
China 201201
Tel: +86-21-28994176
Fax: +86-21-51118446

Mexico
Cooper Tools
de México S.A. de C.V.
a company of
Apex Tool Group, LLC
Vialidad El Pueblito #103
Parque Industrial Querétaro
Querétaro, QRO 76220
Mexico
Tel: +52 (442) 211-3800
Fax: +52 (442) 103-0443

Brazil
Cooper Tools Industrial Ltda.
a company of
Apex Tool Group, LLC
Av. Liberdade, 4055
Zona Industrial - Iporanga
SP Brazil
Tel: +55 15 2383929
Fax: +55 15 2383260

Hungary
Cooper Tools Hungaria Kft.
a company of
Apex Tool Group, LLC
Berkenyefa sor 7
Pf: 640
9027 Győr
Hungary
Tel: +36 96 66 1383
Fax: +36 96 66 1135

Apex Tool Group, LLC
1000 Lufkin Road
Apex, NC 27539
Phone: 919-387-0099
Fax: 919-387-2614
www.apextoolgroup.com

DOTCO®