

Instruction Manual  
PL70-1055EN  
07/08/2013

**OMEGA TECHNOLOGIES**

# Cleco®

**MK Series**  
Radial Piston Power Motors

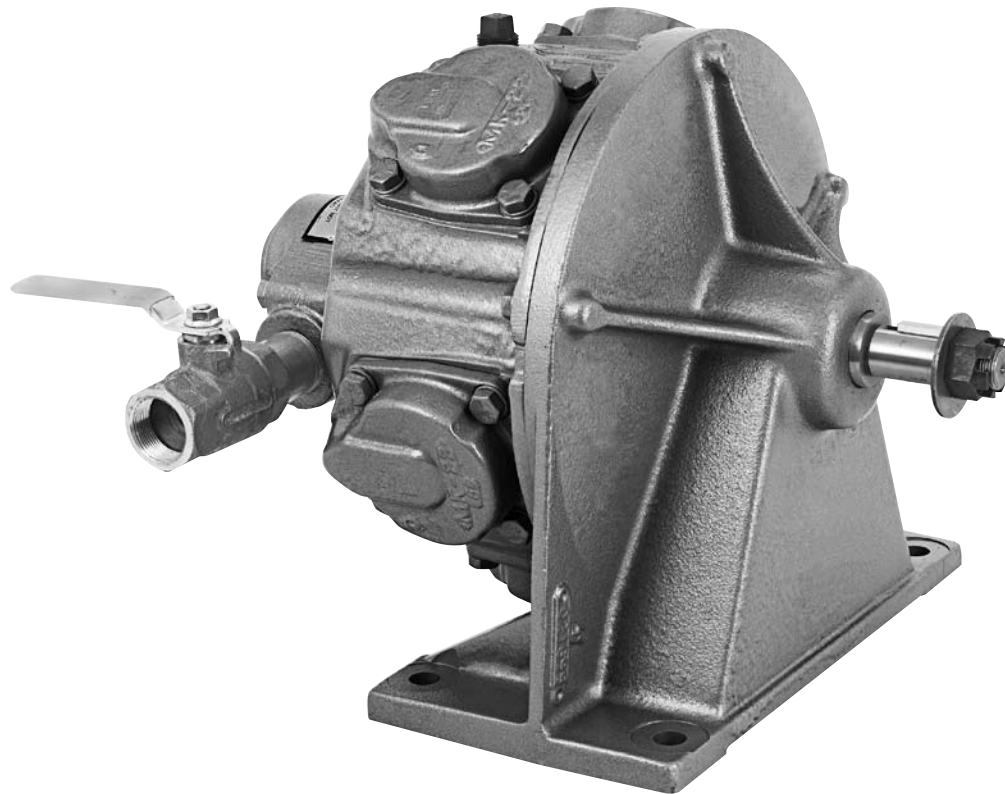

*For additional product information visit our website at:  
<https://dotcotool.com/product-category/cleco-tools/cleco-air-motors/cleco-mk-series-radial-piston-air-motors/>*

## For this Instruction Manual

This Instruction Manual is the Original Instruction Manual intended for all persons who will operate and maintain these tools.

This Instruction Manual

- provides important notes for the safe and efficient use of these tools.
- describes the function and operation of the MK series tools.
- serves as a reference guide for technical data, service intervals and spare parts ordering.
- provides information on optional equipment.

### Identification text:

MK	represents all models of the radial piston power motor as described in this manual
→	indicates a required action
•	indicates a list
<..>	indicates a reference number from the exploded parts drawings
<b>Arial</b>	indicates an important feature or instruction written in <b>Arial Bold</b>

### Identification graphic:

→	indicates a directional movement
↓	indicates a function or force

### Copyright protection:

Apex Tool Group, LLC reserves the right to modify, supplement or improve this document or the product without prior notice. This document may not be reproduced in any way, shape or form, in full or parts thereof, or copied to another natural or machine readable language or to a data carrier, whether electronic, mechanical, optical or otherwise without the express permission of Apex Tool Group, LLC.

**Cleco®**  
Nomenclature

**PL70-1055EN**  
07/08/2013

Model Number	Maximum Allowable RPM**		Stall Torque		Starting Torque		Weight		Air Consumption		Gear Ratio	Maximum Overhung Load @ Stall *	
	@ Max. HP	Free Speed	ft. lbs.	Nm	ft. lbs.	Nm	lbs.	kg	cfm	m3/min		lbs.	kg
<b>Single Direction Valving</b>													
MKS390M	975	1900	117	159	72	98	195	88.5	302	8.55	----	2500	1134
MKS392M	69	135	1654	2243	1021	1384	225	102.1	293	8.30	14.2:1	2800	1270
<b>Reversible Valving</b>													
MKR391M	975	1900	117	159	72	98	202	91.6	311	8.81	----	2500	1134
MKR395M	183	375	606	822	374	507	230	104.3	299	8.47	5.2:1	2800	1270
MKR393M	67	135	1654	2243	1021	1384	230	104.3	288	8.16	14.2:1	2800	1270
<b>without Valving</b>													
MKW418M	975	1900	117	159	72	98	104	91.6	311	8.81	----	2500	1134
MKW420M	183	375	606	822	374	507	230	104.3	299	8.47	5.2:1	2800	1270
MKW419M	67	135	1654	2243	1021	1384	230	104.3	288	8.16	14.2:1	2800	1270

\* Note: All models assume overhung load located at 1.000" (25.40mm) from the face of the motor.

\*\*Note: These motors must be operated with sufficient load to prevent speed from exceeding maximum allowable speed.

<b>1</b>	<b>Safety</b>	<b>6</b>
1.1	Warning and notes.....	6
1.2	Basic requirements for safe working practices .....	7
1.3	Operator training.....	7
1.4	Personal protective equipment .....	7
1.5	Designated use.....	8
1.6	Codes and standards .....	8
1.7	Noise and vibration.....	8
<b>2</b>	<b>Scope of supply, transport and storage</b>	<b>9</b>
2.1	Items supplied .....	9
2.2	Transport .....	9
2.3	Storage.....	9
<b>3</b>	<b>Product description</b>	<b>10</b>
3.1	General description .....	10
3.2	Operation and functional elements.....	10
<b>4</b>	<b>Accessories</b>	<b>11</b>
<b>5</b>	<b>Before initial operation</b>	<b>12</b>
5.1	Ambient conditions .....	12
5.2	Air supply.....	12
5.3	Connecting the air supply to the tool .....	12
5.4	Tool set up .....	13
<b>6</b>	<b>First operation</b>	<b>14</b>
6.1	Putting into use.....	14
<b>7</b>	<b>Troubleshooting</b>	<b>15</b>
<b>8</b>	<b>Maintenance</b>	<b>16</b>
8.1	Service schedule .....	16
8.2	Lubricants .....	17
<b>9</b>	<b>Repair instructions</b>	<b>18</b>
9.1	Motor case assembly.....	18
9.2	Direct drive models: assembly.....	18
9.3	Geared models: assembly.....	20

<b>10</b>	<b>Spare parts</b>	<b>22</b>
10.1	MK Series Direct Drive Power Motor.....	22
10.2.1	MK Series Geared Power Motor.....	24
10.2.2	MK Series Geared Power Motor.....	26
10.3	Single Direction Valving.....	28
10.4	Reversible Valving.....	28
<b>11</b>	<b>Technical data</b>	<b>30</b>
11.1	MK Specifications.....	30
<b>12</b>	<b>Service</b>	<b>31</b>
12.1	Replacement parts.....	31
12.2	Tool repairs.....	31
12.3	Warranty repairs.....	31
<b>13</b>	<b>Disposal</b>	<b>32</b>

# 1 Safety

## 1.1 Warnings and notes

Warning notes are identified by a signal word and a pictogram.

- The signal word indicates the severity and probability of the impending danger.
- The pictogram indicates the type of danger.

WARNING!



**WARNING** identifies a potentially **hazardous** situation which, if not avoided, may result in serious injury.

CAUTION!



**CAUTION** identifies a potentially **hazardous** situation which, if not avoided, may result in minor or moderate injury or property and environmental damage.

NOTE



**NOTE** identifies general information which may include application tips or useful information but no hazardous situations.



Important information that must be read and understood by all personnel installing, operating or maintaining this equipment.

## 1.2 Basic requirements for safe working practices



All personnel involved with the installation, operation or maintenance of these tools must read and understand all safety instructions contained in this manual. Failure to comply with these instructions could result in serious injury or property damage.

These safety instructions are not intended to be all inclusive. Study and comply with all applicable National, State and Local regulations.

---

**CAUTION!!**

### **Work Area:**



- Ensure there is enough space in the work area.
- Keep the work area clean.
- Keep the work area well ventilated.

### **Personnel Safety:**

- Inspect the air supply hoses and fittings. Do not use damaged, frayed or deteriorated hoses.
- Make sure the air supply hose is securely attached to the tool.
- Install adequate guards for all moving parts of the power motor or it's application.

### **Safety working with and around power motors:**

- Make sure the motor is securely mounted to the application.
  - Make sure the output spindle is fully engaged with the application.
  - Disconnect the air supply before servicing the motor
- 

## 1.3 Operator training

All personnel must be properly trained before operating the MK tools. The MK tools are to be repaired by fully trained personnel only.

## 1.4 Personal protective equipment

When working



- Wear eye protection to protect against flying metal splinters.
- Wear hearing protection

Danger of injury by being caught by moving equipment.



- Wear a hair net
- Do not wear close fitting clothing
- Do not wear jewelry

### **1.5 Designated use**

The ME is designed exclusively as a power source to be integrated into an application.

- Do not modify the MK, any guard or accessory.
- Use only with accessory parts which are approved by the manufacturer.
- Do not use in any improper manner that can cause damage to the motor.

### **1.6 Codes and standards**

It is mandatory that all national, state and local codes and standards be followed.

### **1.7 Noise and vibration**

No data available on this equipment.



**Scope of Supply, Transport and Storage****2 Scope of supply, transport and storage****2.1 Items supplied**

Check shipment for transit damage and ensure that all items have been supplied:

- 1 MK
- 1 PL70-1055EN instruction manual
- 1 Declaration of Conformity (if applicable)
- 1 Lubrication sheet
- 1 Warranty statement

**2.2 Transport**

Transport and store the MK in the original packaging. The packaging is recyclable.

**2.3 Storage**

For short term storage (less than 2 hours) and protection against damage:

→ Place the MK in a location on the workbench to avoid accidental startup.

For storage longer than 2 hours:

→ Disconnect the air supply from the MK

<b>Object</b>	<b>Time Period</b>	<b>Storage Temperature</b>
MK without air supply	No guideline	-13°F to 104°F (-25°C to 40°C)

### 3 Product description

#### 3.1 General description

- Pneumatic powered radial piston power motor
- 11 Horsepower
- Direct drive or geared model options
- No valving, single direction valving and reversible valving options

#### 3.2 Operation and functional elements

This section describes the operational and functional elements of the MK.

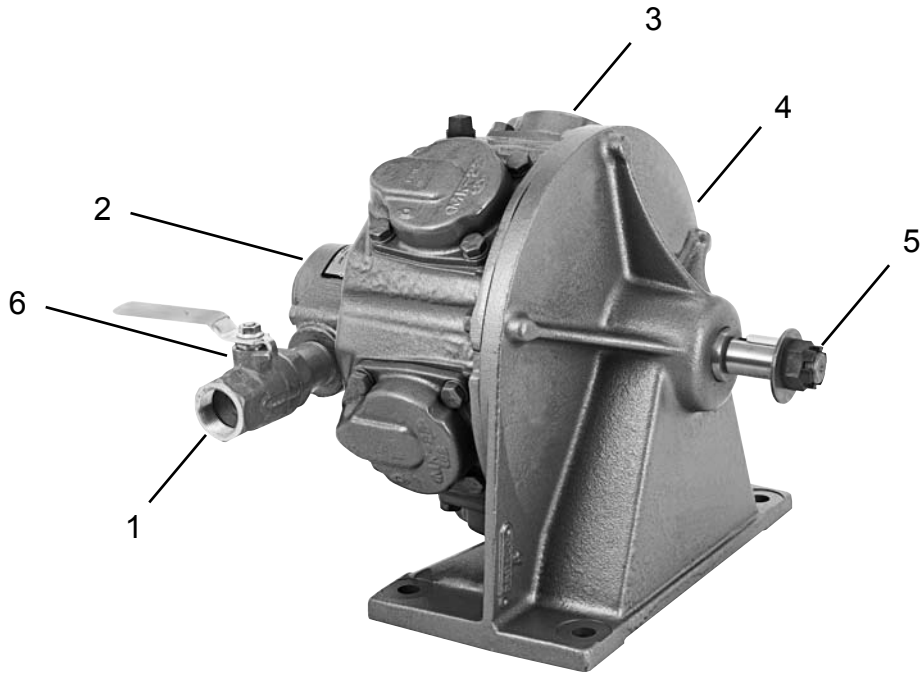

Ref.	Description
1	Air Inlet
2	Valve Chest
3	Motor Assembly
4	Gearing Assembly
5	Output Shaft
6	Single Direction Plumbing (MKS models)

**4 Accessories**

## 5 Before initial operation

### 5.1 Ambient conditions

Ambient temperature: 41°F (5°C) to a maximum of 104°F (40°C)

Acceptable relative humidity: 25% to 90%, non-condensing

### 5.2 Air supply

Parameter	Description
Air Hose	Air inlet: 1-1/4" (31,75 mm) Maximum length: 16.4' (5 m)
Working pressure range	60 to 100 psi (414 to 689 kPa) Recommended: 90 psi (620 kPa)
Compressed air	Air quality according to ISO 8573-1, quality class 2.4.3 The compressed air must be clean and dry.

**NOTE**



To attain consistent results, maintain a constant working pressure using a suitable air line unit consisting of a filter, lubricator and regulator.

- The inside diameter of the air hose must be free of residue, clean if necessary.
- If a line lubricator is used, it should be filled daily

#### Oil identification

**Fill the motor to the proper level before operating.**

**Use engine oil API Service Classified "SC" in the following weights:**

- Above 32° F: SAE 30W
- Below 32° F: SAE 10W

### 5.3 Connecting the air supply to the tool

**WARNING!**



The air hose can disconnect from the motor by itself and whip around uncontrollably.

- Turn off the compressed air before connecting to the motor.
- Securely connect the air hose to the motor.
- Turn on the compressed air.

**5.4 Tool set up**

The motor must be configured for the application.

## **6 First operation**

### **6.1 Putting into use**

The MK series motors are a five cylinder radial piston type. This radial design, with its overlap of power impulses, provides even torque at all speeds and full power in either direction of rotation. At least two pistons are always on a power stroke.

These motors are designed for continuous service on 60-100 PSI air pressure. If overloaded beyond their power capacity, the motor will simply stall without causing any damage.

- Make sure the air line is clean and free of scale and dirt before connecting to the motor.
- Make sure all pipe fittings are securely tightened to prevent air leaks.
- Make sure the air supply is securely attached and the compressor is turned on.
- Make sure the output spindle is properly engaged with the application.
- Make sure all necessary guards are in place to protect operator from rotating mechanisms.

**Continuous Operation:** Do not operate the MK motors faster than 65% of free speed. Install a filter/lubricator unit in the air line as close as possible to the MK motor.

**Intermittent Operation:** The splash lubrication from the motor case will be adequate.

If an excessive amount of water is found in the air line, a water trap should be installed to trap as much as possible before it reaches the MK motor.

## 7 Troubleshooting

<b>Malfunction</b>	<b>Possible causes</b>	<b>Remedy</b>
Tool does not start	Improper air supply	→ Make sure there is adequate air pressure at the tool air inlet
	Motor dry from lack of lubrication	→ Check the oil levels in the motor case and gear case. Add oil as necessary.
	Broken gears	→ Tool disassembly required (parts replacement)
Tool runs slow and lacks torque	Improper air supply	→ Make sure there is adequate air pressure at the tool air inlet
	Motor dry from lack of lubrication	→ Check the oil levels in the motor case and gear case. Add oil as necessary.

## 8 Maintenance

---

CAUTION!



Danger of injury from accidental start up.  
Turn off the compressed air before performing any maintenance.

---

### 8.1 Service schedule

Only qualified and trained personnel are permitted to perform maintenance on these motors.

Regular maintenance reduces operating faults, repair costs and downtime. In addition to the following service schedule, implement a safety related maintenance program that takes the local regulations for repair and maintenance for all operating phases of the motor into account.

Maintenance Interval	Designation
Daily	<ul style="list-style-type: none"><li>→ Visual inspection of air supply hose and connections</li><li>→ Inspect airline filter, regulator and lubricator for proper operation</li><li>→ Check the tool for excessive vibration or unusual noises</li><li>→ Visual inspection of all external components of the tool</li></ul>
Weekly	<ul style="list-style-type: none"><li>→ Inspect the air hose for damage or wear</li><li>→ inspect the output spindle for damage or wear</li><li>→ Inspect the breather cap to make sure it is not plugged, clean or replace</li><li>→ Remove the motor case drain plug to allow water and condensate to drain out</li><li>→ Check oil levels in the motor case and gear case, add as necessary</li></ul>



## 8.2 Lubricants

For proper function and long service life, use of the correct lubricant is essential.

### Oil identification

Fill the motor to the proper level before operating.

Use engine oil API Service Classified "SC" in the following weights:

- Above 32° F: SAE 30W
- Below 32° F: SAE 10W

If the air line carries an excessive amount of water and a water trap cannot be installed, use a good grade of motor oil that will emulsify with water to prevent damage to vital parts of the motor.

### Oil quantity

Approximately 1-1/2 quarts of oil are required to fill the motor case to the proper oil level.

Approximately 1 quart of oil is required to fill the gear case to the proper oil level. The oil must flow at all times to properly lubricate the motor components, gears and bearings.

To check the MK for proper oil level, open the oil level pet cock. If oil does not flow from the pet cock, add the proper oil until oil begins to flow. Securely tighten the oil level pet cock.

Remove the oil drain plug in the motor case occasionally and drain off accumulated water before adding new oil.

Excessive use of oil is usually due to:

- Worn pistons
- Worn piston rings
- Worn distributing valve and bushing
- Damaged oil seals
- Clogged breather cap

## 9 Repair instructions

### 9.1 Motor case assembly

Install the pin (DP114) into the motor case until approximately 1/8" is exposed in the distributing valve bushing hole.

Install the valve bushing (MK11) into the motor case counter bore until it is flush with the inside edge of the counter bore. The valve bushing has a slot to enable proper alignment during assembly.

**NOTE**



***The valve bushing must be placed in a freezer, for a period of time, before assembling into the motor case. This will cause the bushing to contract allowing easier assembly into the motor case.***

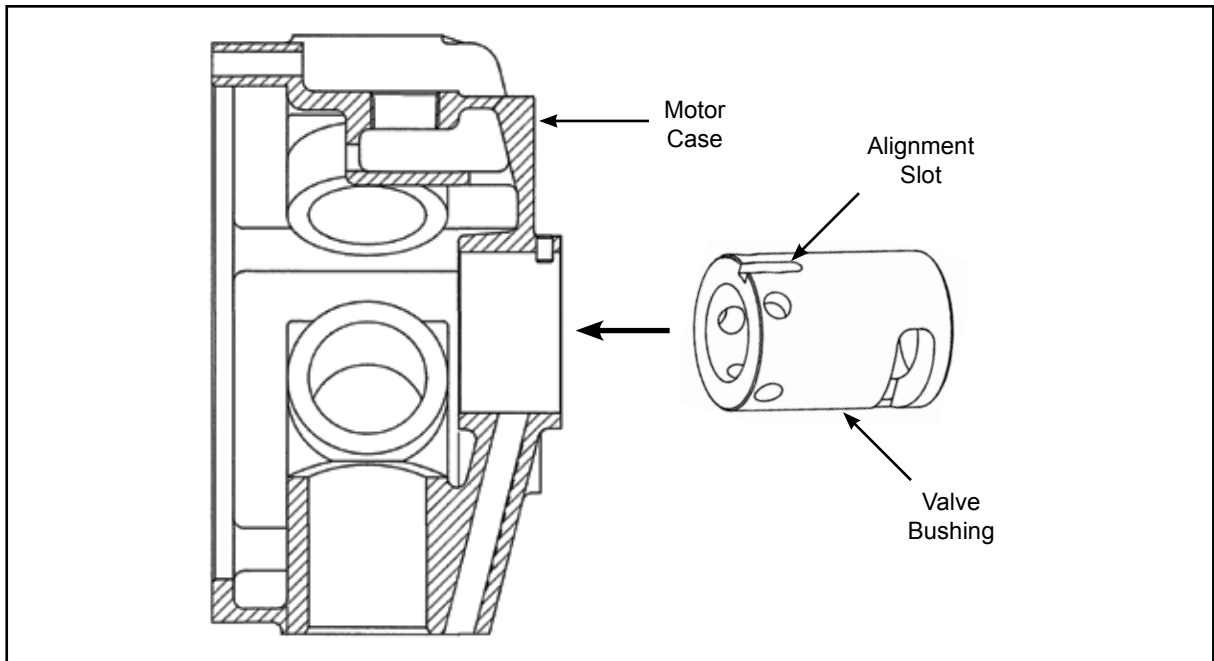

### 9.2 Direct drive models: assembly

- Install the piston rings in the grooves on the pistons. The step on the ring must be toward the open part of the piston.
- Assemble a retainer into one end of the hole in the pistons.
- Slip the bushing (MK33), chamfer down, over the crankshaft (drive end) until it bottoms out. Line up the oil holes with the groove in the crankshaft.
- Put a light coating of oil on the bushing (MK28) and slide it over the bushing (MK33) on the crankshaft.
- Tap the key (35D13) into the keyway on the crankshaft.
- Place one connecting rod retainer over the bushing (MK28). Place the five connecting rods into the connecting rod retainer. Make sure the lettering on the rods are up. Place the other connecting rod retainer over the connecting rods and bushing (MK28).
- Assemble the crankshaft (drive end) to the crankshaft (valve end). Line up the shaft groove with the hole in the crankshaft and insert the screw (MK32). Secure with the nut (50E5) and cotter pin.

## **9.2 Direct drive models: assembly (continued)**

- Press the bearing (12J30) onto the crankshaft assembly until it bottoms out.
- Place the crankshaft assembly into the motor case and tap into position.
- Using the piston pins, attach the five pistons to the connecting rods and secure with the retainers (MK26).
- Place a cylinder gasket on each of the cylinders. Oil the inside of the cylinders.
- Compress the piston rings and slide a cylinder over each piston. Secure the cylinders using the washers (95G24) and screws (75A4). Tighten the screws to 45 ft. lbs. (61 Nm) torque.
- Lightly oil the valve bushing and distributor valve. Insert the distributor valve into the valve bushing (locate in dowel pin).
- Slide the valve chest over the bushing and secure with two washers (95G24) and screws (75A208). Tighten the screws to 45 ft. lbs. (61 Nm) torque.
- Apply air to the unit and test run in one direction only.
- Press the bearing (12GG2) into the frame until it bottoms out.
- Place the bearing (12J15) onto the non-threaded end of the shaft until it bottoms out.
- Tap the key (35B207) into the motor shaft keyway.
- Place the shaft assembly into the crankshaft assembly and tap in until it bottoms out.
- Place the gasket on the motor case and assemble the motor case to the motor frame, breather hole up. Secure with washers (95G24) and screws (75A12). Tighten the screws to 45 ft. lbs (61 Nm) torque.
- Assemble the pipe plugs and drain cock. Fill the motor case with 2 quarts of oil.

# Cleco® Repair Instructions

## 9.3 Geared models: assembly

- Press the bearing (525424) onto the large gear end of the gear and pinion.
- Press the bearing (526576) onto the geared end of the gear and shaft until it bottoms out. Press the bearing (12J37) and then the wear ring (MKGP40R) onto the threaded end of the gear and shaft until they bottom out.

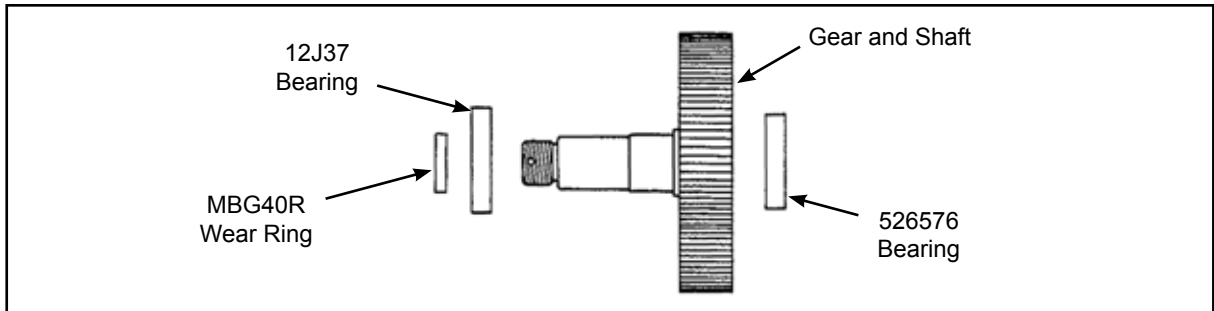

- Press the oil seal (60G115) into the gear housing until it is flush with the outside edge of the housing.
- Press the gear and pinion bearing (523576) into the housing until it bottoms out.
- Insert the gear and shaft assembly into the gear housing and tap in until it bottoms out.
- Install the gear and pinion assembly into the gear housing.

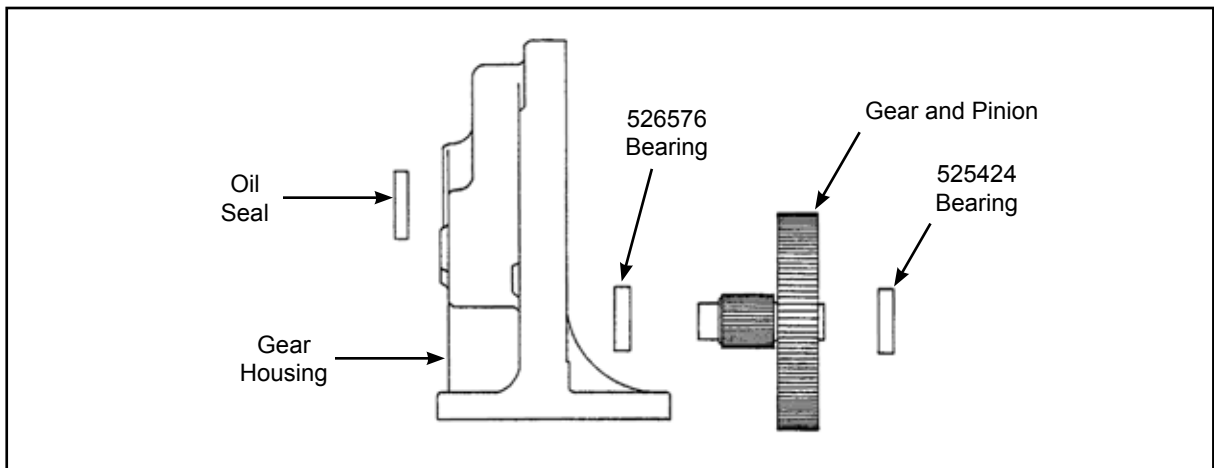

- Press the oil seal (60G116) into the bearing housing (MK20)
- Place the bearing housing (MK39) on the bearing housing (MK20) and secure with three washers (W125) and screws (75B4). Tighten the screws to 45 ft. lbs. (61 Nm) torque.
- Place the gasket (HK25) over the gear housing and assemble the bearing housing. Make sure the pin in the bearing housing (MK20) fits into the mating hole in the gear housing.
- Press the bearing (12J37) onto the pinion gear until it bottoms out. Tap the key (35D13) into the pinion gear keyway. Insert the pinion gear assembly into the crankshaft assembly until it bottoms out.

### **9.3 Geared models: assembly (continued)**

- Install the piston rings in the grooves on the pistons. The step on the ring must be toward the open part of the piston.
- Assemble a retainer into one end of the hole in the pistons.
- Slip the bushing (MK33), chamfer down, over the crankshaft (drive end) until it bottoms out. Line up the oil holes with the groove in the crankshaft.
- Put a light coating of oil on the bushing (MK28) and slide it over the bushing (MK33) on the crankshaft.
- Tap the key (35D13) into the keyway on the crankshaft.
- Place one connecting rod retainer over the bushing (MK28). Place the five connecting rods into the connecting rod retainer. Make sure the lettering on the rods are up. Place the other connecting rod retainer over the connecting rods and bushing (MK28).
- Assemble the crankshaft (drive end) to the crankshaft (valve end). Line up the shaft groove with the hole in the crankshaft and insert the screw (MK32). Secure with the nut (50E5) and cotter pin.
- Press the bearing (12J30) onto the crankshaft assembly until it bottoms out.
- Place the crankshaft assembly into the motor case and tap into position.
- Using the piston pins, attach the five pistons to the connecting rods and secure with the retainers (MK26).
- Place a cylinder gasket on each of the cylinders. Oil the inside of the cylinders.
- Compress the piston rings and slide a cylinder over each piston. Secure the cylinders using the washers (95G24) and screws (75A4). Tighten the screws to 45 ft. lbs. (61 Nm) torque.
- Lightly oil the valve bushing and distributor valve. Insert the distributor valve into the valve bushing (locate in dowel pin).
- Slide the valve chest over the bushing and secure with two washers (95G24) and screws (75A208). Tighten the screws to 45 ft. lbs. (61 Nm) torque.
- Apply air to the unit and test run in one direction only.
- Place the gasket on the motor case and assemble the motor case to the gear housing assembly, breather hole up. Secure with washers (95G24) and screws (B154 M). Tighten the screws to 45 ft. lbs (61 Nm) torque.
- Assemble the pipe plugs and drain cock. Fill the motor case with 2 quarts of oil and the gear housing with 1 quart of oil.

**10.1 MK Series Direct Drive Power Motor**

**Model**

MKW418M (without valving)  
MKS390M (single direction)  
MKR391M (reversible)

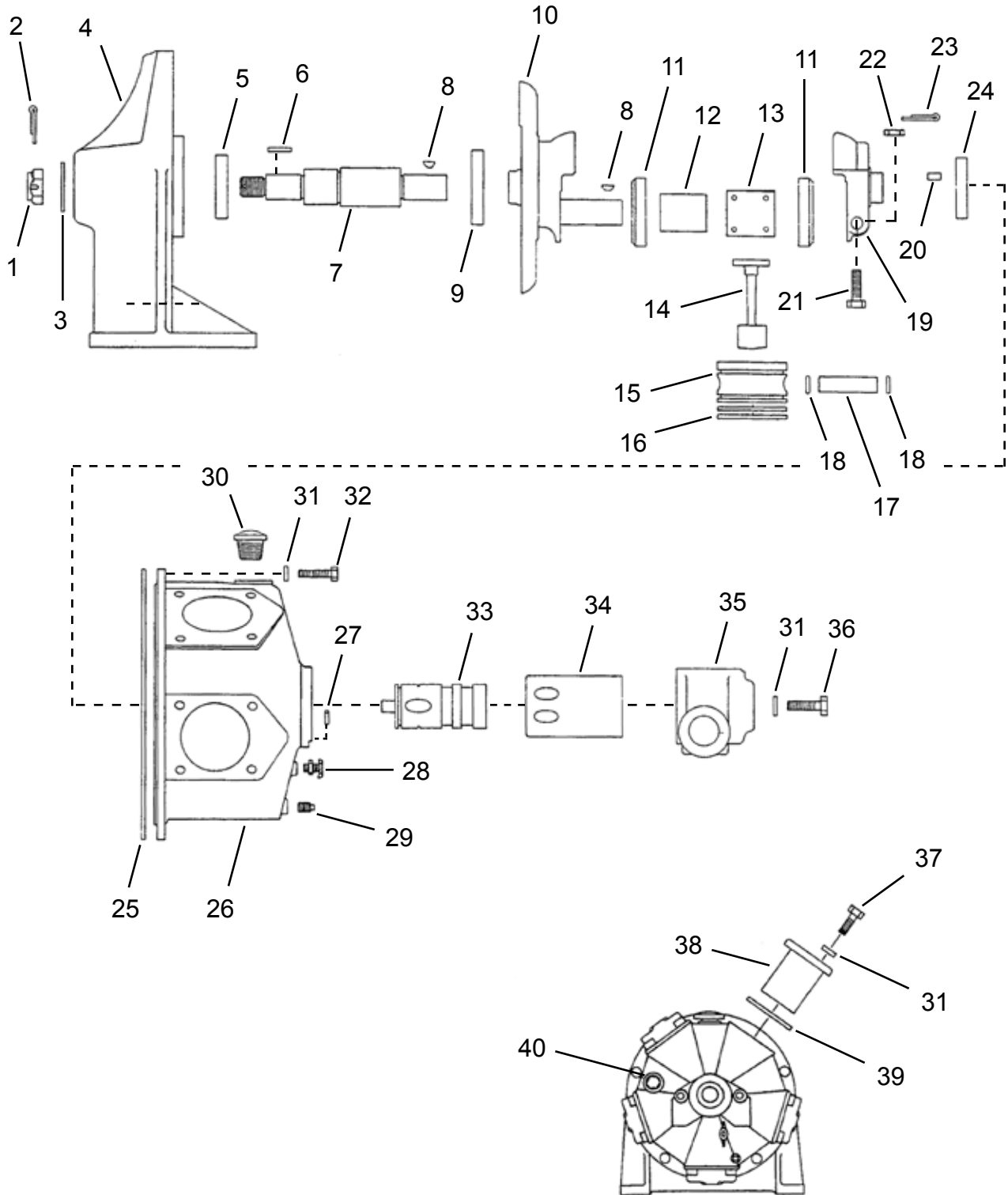

**10.1 MK Series Direct Drive Power Motor**

Ref	Number	#	X	EN
				Description
1	50E11	1	2	Output Shaft Hex Nut
2	62E9	1	3	Cotter Pin
3	95A10	1	2	Output Shaft Washer
4	MKA7	1		Motor Frame
5	12GG2	1	2	Ball Bearing
6	35B207	1	3	Motor Shaft Key
7	MKA3	1		Motor Shaft
8	35D13	2	6	Woodruff Key
9	12J15	1	2	Ball Bearing
10	MK30Y	1		Crankshaft (Drive End)
11	MK29	2		Connecting Rod Retainer
12	MK33	1		Crankshaft Bushing
13	MK28	1		Connecting Rod Bushing
14	MK27	5		Connecting Rod
15	MK24	5		Piston
16	65A222	10	10	Piston Ring
17	MK25	5		Piston Pin
18	MK26	10	10	Piston Pin Retainer
19	MK31	1		Crankshaft (Valve End) (includes Ref. 20)
20	DP142	1	2	Crankshaft Pin
21	MK32	1	1	Crankshaft Bolt
22	50E5	1	2	Hex Castle Nut
23	P101J	1	3	Cotter Pin
24	12J30	1	2	Ball Bearing
25	MK19	1	3	Motor Case Gasket
26	MK18	1		Motor Case (includes Ref. 27)
27	DP114	1		Motor Case Pin
28	90C12	1	2	Drain Cock
29	64AA5	1		Pipe Plug
30	542139	1	2	Low Profile Breather Cap
31	95G24	27	27	Flat Washer
32	75A12	5	5	Motor Case Screw
33	MKL13	1		Distributing Valve
34	MK11	1		Distributing Valve Bushing
35	533763	1		Valve Chest
36	75A208	2	2	Valve Chest Screw
37	75A4	20	20	Cylinder Screw
38	MK22	5		Cylinder
39	MK23	5	15	Cylinder Gasket
40	64A5	1		Pipe Plug

(#) Quantity

(X) Recommended Spare Parts (quantity shown based on 1-5 tools in operation)

**10.2.1 MK Series Geared Power Motor**

**Models**

MKW419M	MKS392M	MKR393M
MKW420M		MKR395M

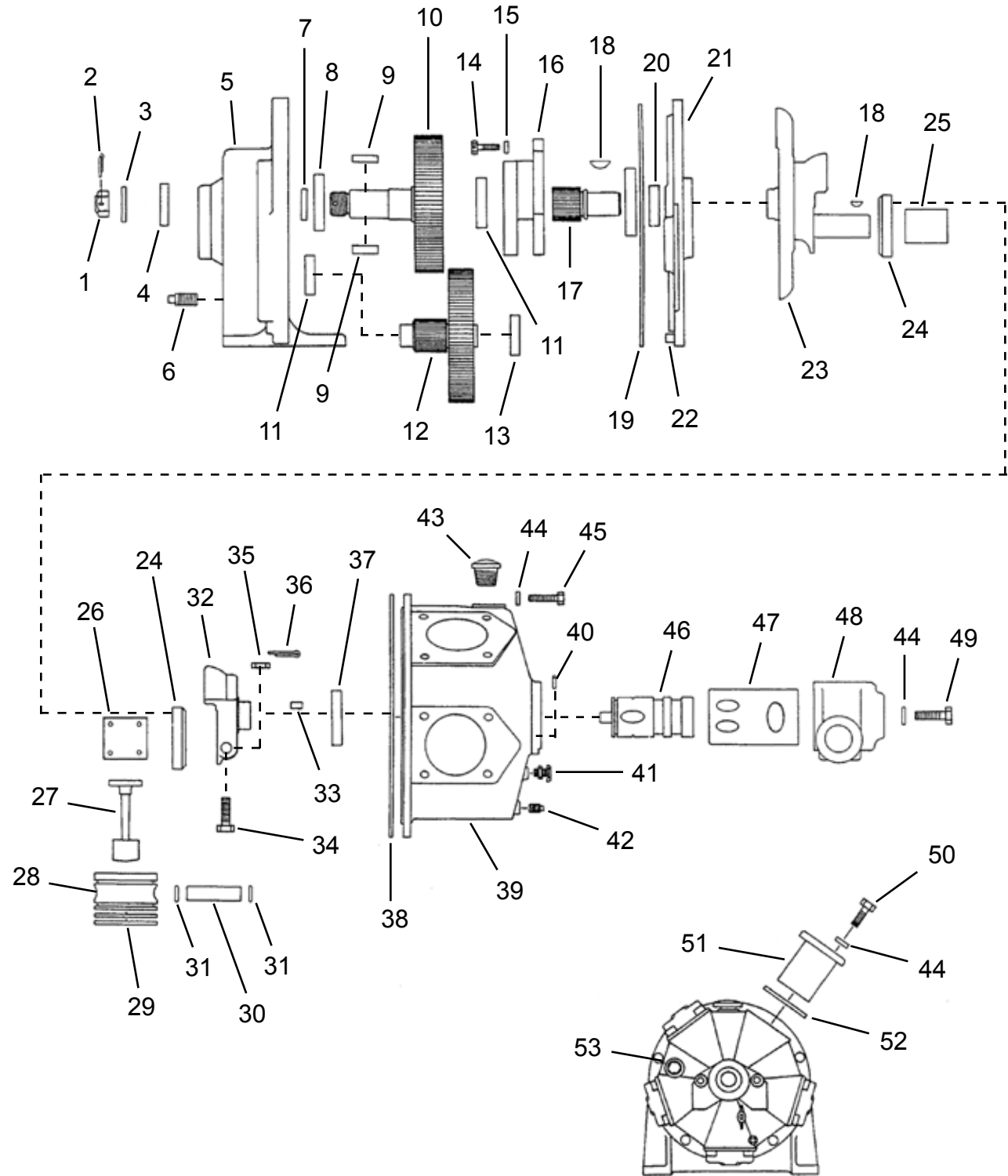



**10.2.1 MK Series Geared Power Motor**

Ref	Number	#	X	EN
				Description
1	MKU52	1	2	Output Shaft Hex Nut
2	62E66	1	3	Cotter Pin
3	95A11	1	2	Output Shaft Washer
4	60G115	1	3	Oil Seal
5	MKG1	1		Gear Housing (includes Ref. 6)
6	B110E	1		Pipe Plug
7	MKGP40R	1	3	Wear Ring
8	12J37	2	4	Ball Bearing
9	35B125	2	4	Gear and Shaft Key
10	Table 10.2.1	1		Gear and Shaft
11	526576	2	4	Ball Bearing
12	Table 10.2.1	1		Gear and Pinion
13	525424	1	2	Ball Bearing
14	75B4	3	3	Bearing Housing Screw
15	W125	3	3	Flat Washer
16	MK39	1		Bearing Housing
17	Table 10.2.1	1		Pinion Gear
18	35D13	2	6	Woodruff Key
19	HK25	1	3	Bearing Housing Gasket
20	60G116	1	3	Oil Seal
21	MK20	1		Bearing Housing (includes Ref. 22)
22	DP162	1		Pin
23	MK30Y	1		Crankshaft (Drive End)
24	MK29	2		Connecting Rod Retainer
25	MK33	1	1	Crankshaft Bushing
26	MK28	1	1	Connecting Rod Bushing
27	MK27	5		Connecting Rod
28	MK24	5		Piston
29	65A222	10	10	Piston Ring
30	MK25	5		Piston Pin
31	MK26	10	10	Piston Pin Retainer
32	MK31	1		Crankshaft (Valve End ) ( includes Ref. 33)
33	DP142	1		Crankshaft Pin
34	MK32	1	1	Crankshaft Bolt

(#) Quantity

(X) Recommended Spare Parts (quantity shown based on 1-5 tools in operation)

**Table 10.2.1**

Ref.	Description	#	MKS392M MKR393M MKW419M	#	MKR395M MKW420M
--	Gear Ratio		14.2:1		5.2:1
--	Valving		Note 1		Note 1
10	Gear and Shaft	1	MKG50S	1	MKG51S
12	Gear and Pinion	1	MK38A	1	MKG38
17	Pinion Gear	1	MK37	1	MKG37

Note 1: MKW = no valving, MKS = Single Direction, MKR = Reversible

**10.2.2 MK Series Geared Power Motor**

**Models**

MKW419M	MKS392M	MKR393M
MKW420M		MKR395M

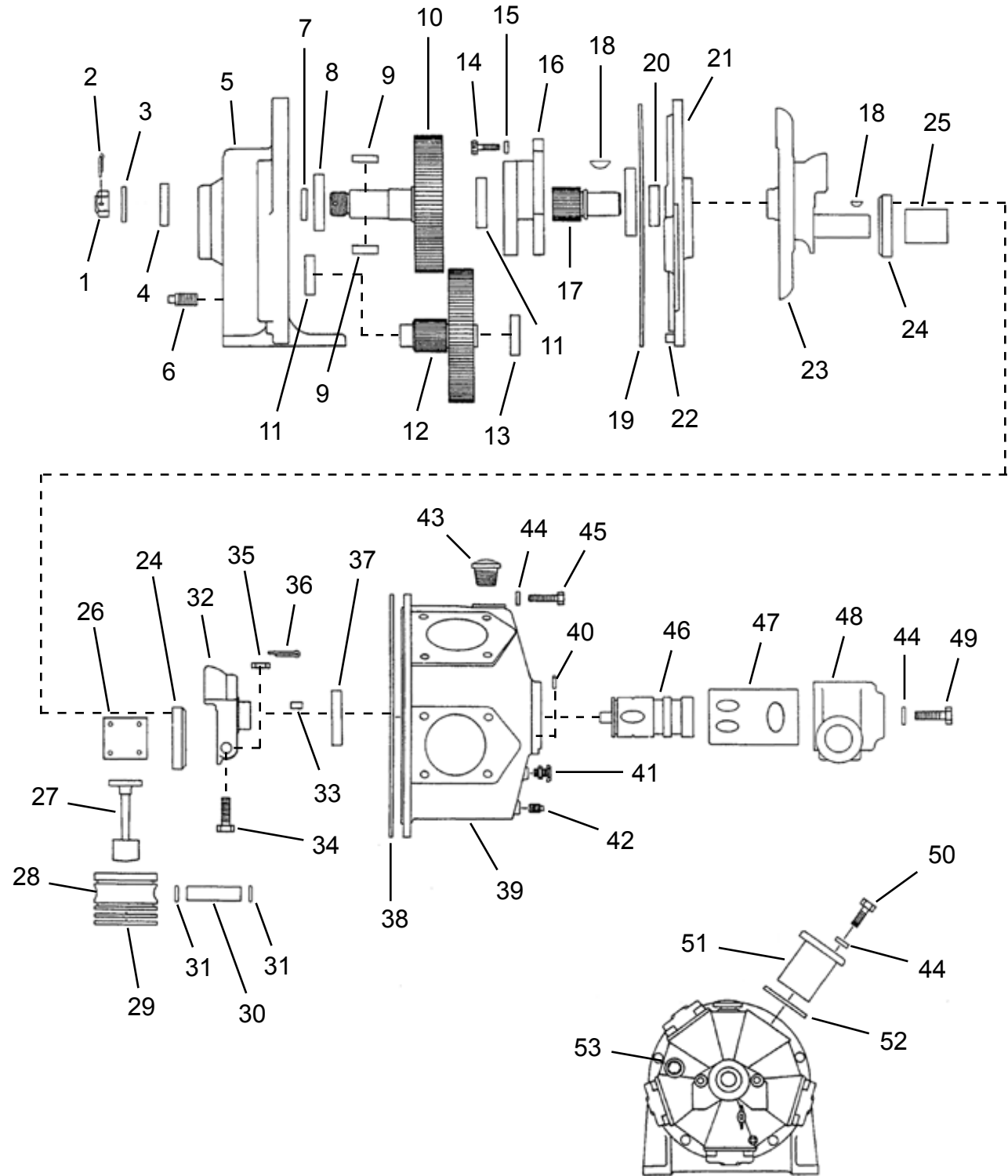

**10.2.2 MK Series Geared Power Motor (continued)**

Ref	Number	#	X	EN
				Description
35	50E5	1	2	Hex Castle Nut
36	P101J	1	3	Cotter Pin
37	12J30	1	2	Ball Bearing
38	MK19	1	3	Motor Case Gasket
39	MK18	1		Motor Case (includes Ref. 40)
40	DP114	1		Motor Case Pin
41	90C12	2	4	Drain Cock
42	64AA5	1		Pipe Plug
43	542139	1	2	Low Profile Breather Cap
44	95G24	27	27	Flat Washer
45	B154M	5	5	Motor Case Screw
46	MKL13	1		Distributor Valve
47	MK11	1		Distributor Valve Bushing
48	533763	1		Valve Chest
49	75A208	2	2	Valve Chest Screw
50	75A4	20	20	Cylinder Screw
51	MK22	5		Cylinder
52	MK23	5	15	Cylinder Gasket
53	64A5	1		Pipe Plug

(#) Quantity

(X) Recommended Spare Parts (quantity shown based on 1-5 tools in operation)

**10.3 Single Direction Valving**

**Models**  
MKS390M  
MKS392M

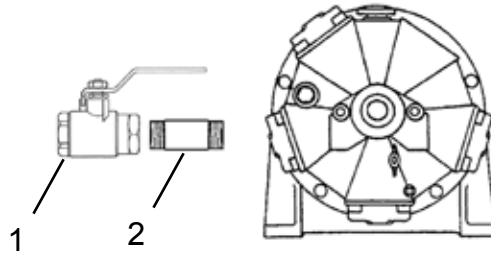

**MK Motor**

**10.4 Reversible Valving**

**Models**  
MKR391M  
MKR393M  
MKR395M

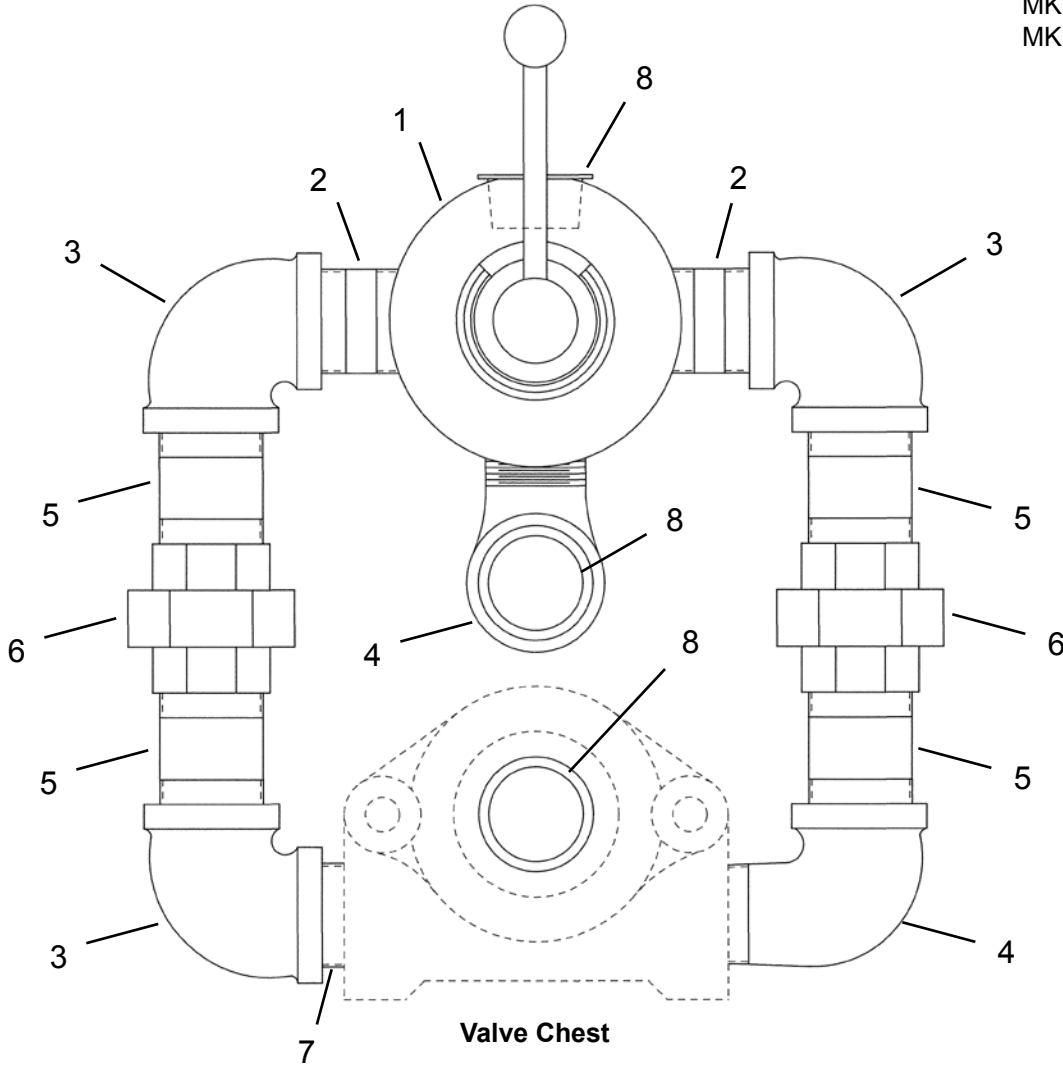

**Valve Chest**

**10.3 Single Direction Valving**

Ref	Number	#	X	EN
				Description
1	90A39	1		Air Control Valve
2	63J11	1		Pipe Nipple

(#) Quantity

(X) Recommended Spare Parts (quantity shown based on 1-5 tools in operation)

**10.4 Reversible Valving**

Ref	Number	#	X	EN
				Description
1	539527	1		4-Way Air Control Valve
2	63J16	2		Pipe Nipple (1-1/4" NPT x 2-1/2" Long)
3	818451	3		90° Elbow (1-1/4" NPT)
4	64D7	2		90° Street Elbow (1-1/4" NPT)
5	63J11	4		Pipe Nipple (1-1/4" NPT x 3" Long)
6	64Z5	2		Union (1-1/4" NPT)
7	63J15	1		Pipe Nipple (1-1/4" NPT x 1-5/8" Long)
8	532320	3		Plastic Plug Cap

(#) Quantity

(X) Recommended Spare Parts (quantity shown based on 1-5 tools in operation)

# 11 Technical data

## 11.1 MK Specifications

Model Number	Maximum Allowable RPM**		Stall Torque		Starting Torque		Weight		Air Consumption		Gear Ratio	Maximum Overhung Load @ Stall *	
	@ Max. HP	Free Speed	ft. lbs.	Nm	ft. lbs.	Nm	lbs.	kg	cfm	m3/min		lbs.	kg
<b>Single Direction Valving</b>													
MKS390M	975	1900	117	159	72	98	195	88.5	302	8.55	----	2500	1134
MKS392M	69	135	1654	2243	1021	1384	225	102.1	293	8.30	14.2:1	2800	1270
<b>Reversible Valving</b>													
MKR391M	975	1900	117	159	72	98	202	91.6	311	8.81	----	2500	1134
MKR395M	183	375	606	822	374	507	230	104.3	299	8.47	5.2:1	2800	1270
MKR393M	67	135	1654	2243	1021	1384	230	104.3	288	8.16	14.2:1	2800	1270
<b>without Valving</b>													
MKW418M	975	1900	117	159	72	98	104	91.6	311	8.81	----	2500	1134
MKW420M	183	375	606	822	374	507	230	104.3	299	8.47	5.2:1	2800	1270
MKW419M	67	135	1654	2243	1021	1384	230	104.3	288	8.16	14.2:1	2800	1270

\* Note: All models assume overhung load located at 1.000" (25.40mm) from the face of the motor.

\*\*Note: These motors must be operated with sufficient load to prevent speed from exceeding maximum allowable speed.

## **12 Service**

### **12.1 Replacement parts**

**NOTE**



Use only original Cleco replacement parts. Failure to comply can result in reduced power and increased service requirements. The tool warranty may be voided if replacement parts are not manufactured or approved by Apex Tool Group.

### **12.2 Tool repairs**

Only qualified and trained personnel are to repair this equipment.

### **12.3 Warranty repairs**

All warranty repairs are to be performed by an authorized Apex Tool Group service center. Contact your local representative for assistance with warranty repair claims.

## 13 Disposal

---

**CAUTION!**

Injuries and environmental damage from improper disposal.



Components and auxiliary materials of the tool pose risks to health and the environment.

- Capture auxiliary materials (oils, greases) when drained and dispose of them properly.
- Separate the packaging components and dispose of them properly.
- Comply with all applicable local regulations.



Observe local disposal guidelines for all components of this tool and its packaging.

---









## Sales & Service Centers

**Note:** All locations may not service all products. Please contact the nearest Sales & Service Center for the appropriate facility to handle your service requirements.

Detroit, Michigan

**Apex Tool Group  
Sales & Service Center**  
2630 Superior Court  
Auburn Hills, MI 48326  
Tel: (248) 393-5640  
Fax: (248) 391-6295

Houston, Texas

**Apex Tool Group  
Sales & Service Center**  
6550 West Sam Houston  
Parkway North, Suite 200  
Houston, TX 77041  
Tel: (713) 849-2364  
Fax: (713) 849-2047

Lexington, South Carolina

**Apex Tool Group**  
670 Industrial Drive  
Lexington, SC 29072  
Tel: (800) 845-5629  
Tel: (803) 951-7544  
Fax: (803) 358-7681

Los Angeles, California

**Apex Tool Group  
Sales & Service Center**  
6881 Stanton Avenue  
Unit B  
Buena Park, CA 90621  
Tel: (714) 994-1491  
Fax: (714) 994-9576

Seattle, Washington

**Apex Tool Group  
Sales & Service Center**  
2865 152nd Avenue N.E.  
Redmond, WA 98052  
Tel: (425) 497-0476  
Fax: (425) 497-0496

York, Pennsylvania

**Apex Tool Group  
Sales & Service Center**  
3990 East Market Street  
York, PA 17402  
Tel: (717) 755-2933  
Fax: (717) 757-5063

Brazil

**Apex Tool Group  
Sales & Service Center**  
Av. Liberdade, 4055  
Zona Industrial - Iporanga  
18087-170 Sorocaba  
SP Brazil  
Tel: +55 15 2383929  
Fax: +55 15 2383260

Canada

**Apex Tool Group  
Sales & Service Center**  
7631 Bath Road  
Mississauga, Ont. L4T  
3T1  
Canada  
Tel: (866) 691-6212  
Tel: (905) 673-4400

China

**Cooper (China) Co., Ltd.**  
an Apex Tool Group, LLC  
company  
955 Sheng Li Road,  
Heqing Pudong, Shanghai  
China 201201  
Tel: +86-21-28994176  
Fax: +86-21-51118446

England

**Apex Tool Group  
GmbH & Co. OHG**  
C/O Spline Gauges  
Piccadilly, Tamworth  
Staffordshire B78 2ER  
United Kingdom  
Tel: +44 1827 8741 28  
Fax: +44 1827 8741 28

France

**Apex Tool Group S.N.C.**  
25 rue Maurice Chevalier  
B.P. 28  
77831 Ozoir-La-Ferrière  
Cedex, France  
Tel: +33 1 64 43 22 00  
Fax: +33 1 64 43 17 17

Germany

**Apex Tool Group  
GmbH & Co. OHG**  
Industriestraße 1  
73463 Westhausen  
Germany  
Tel: +49 (0) 73 63 81 0  
Fax: +49 (0) 73 63 81 222

Hungary

**Apex Tool Group  
Hungaria Kft**  
Platánfa u.2  
9027 Győr  
Hungary  
Tel: +36 96 66 1383  
Fax: +36 96 66 1135

India

**Apex Power Tools India  
Private Limited**  
Gala No. 1, Plot No. 5  
S. No. 234, 235 & 245  
Indialand Global  
Industrial Park  
Taluka-Mulsi, Phase I  
Hinjawadi, Pune 411057  
Maharashtra, India

Mexico

**Apex Tool Group México  
S. de R.L. de C.V.**  
Vialidad El Pueblito #103  
Parque Industrial Querétaro  
Querétaro, QRO 76220  
Mexico  
Tel: +52 (442) 211-3800  
Fax: +52 (442) 103-0443

Apex Tool Group, LLC  
1000 Lufkin Road  
Apex, NC 27539  
Phone: 919-387-0099  
Fax: 919-387-2614  
www.apextoolgroup.com

# Cleco®