

Parts Manual  
PL12-18EA-F  
04/04/2011

# Cleco®

**OMEGA TECHNOLOGIES**

**18EA... Series**  
Electronically Controlled Flush Socket Nutrunner



For additional product information visit our website at:  
<https://dotcotool.com/product-category/cleco-tools/cleco-corded-electric-nutrunners-cleco-air-tools/cleco-18-series-transducer-control-flush-socket-corded-electric-nutrunners-cleco-corded-electric-nutrunners-cleco-air-tools/>

Model Nomenclature

**“A”**

<b>18</b>	<b>E</b>	<b>A</b>	<b>X</b>	<b>XX</b>	<b>F1</b>	<b>XX</b>	<b>X</b>	<b>X</b>
-----------	----------	----------	----------	-----------	-----------	-----------	----------	----------

Tool Series

**18**

Motor Style

**E** = Brushless electric motor

Tool Type

**A** = Right Angle

Feature 1

- = Matrix Tool Connector (Standard)

**E** = Air LB Connector

Maximum Output Torque (Select one)

**16** = 16 Nm

**23** = 23 Nm

**30** = 30 Nm

Tool Termination

**F1** = Flush Socket

Drive Socket

**EB** = 5/16"

**MB** = 8mm

**XX** = Special

**EE** = 1/2"

**MD** = 10mm

**00** = No Socket

**EF** = 9/16"

**ME** = 11mm

**01** = First Special

**MF** = 12mm

**02** = Second Special

**MG** = 13mm

etc.

**MH** = 14mm

**MI** = 15mm

Extension

**0** = Flush

**6** = 3/4"

**2** = 1/4"

**8** = 1"

**4** = 1/2"

Output Type

**0** = Standard

**1** = Fast Lead

**2** = Magnetic

**“B”**

<b>Complete Tool</b>
<b>Order Number</b>
<b>Ordnen Sie Zahl an</b>
<b>Commander le Numéro</b>
<b>El Número de pedido</b>
<b>Ordinare il Numero</b>
18EA(E)16F1xxx
18EA(E)23F1xxx
18EA(E)30F1xxx

TME-200 Series  
Controller



m-Pro-400 Series  
Controller



Tool Cable

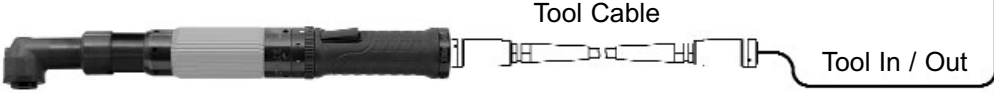

Tool In / Out

18EA	18EAE	EN	DE	FR	ES	IT
		Description	Benennung	Designation	Descripción	Descrizione
TME-200	m-Pro-400	Controller				
PL12( )-1300	*	Programming Notes	Programmierenanmerkungen	Notes de programmation	Notas de programación	Note di programmazione
575708	*	Battery	Batterie	Batterie	Bateria	Batteria
541683-01	*	Power Cord 115VAC - USA	Anschlußkabel 115VAC - USA	Cordon d'alimentation 115VAC - USA	Cable de potencia 115VAC - USA	Cordone d'alimentazione 115VAC - USA
541683-02	*	Power Cord 230VAC - USA	Anschlußkabel 230VAC - USA	Cordon d'alimentation 230VAC - USA	Cable de potencia 230VAC - USA	Cordone d'alimentazione 230VAC - USA
541683-03	*	Power Cord 230VAC - Europe	Anschlußkabel 230VAC - Europa	Cordon d'alimentation 230VAC - L'Europe	Cable de potencia 230VAC - Europa	Cordone d'alimentazione 230VAC - Europa
542779-XXX	960430-XXX	Extension Cable	Verlängerung Kabel	Câble De Prolongation	Cable De la Extensión	Cavo Di Estensione
544056-XXX	961251-XXX	Swivel Cable	Schwenker-Kabel	Câble De Pivot	Cable Del Eslabón giratorio	Cavo Della Parte girevole
544055-XXX	961252-XXX	Swivel Cable (90°)	Schwenker-Kabel (90°)	Câble De Pivot (90°)	Cable Del Eslabón giratorio (90°)	Cavo Della Parte girevole (90°)
542778-XXX	961250-XXX	Tool Cable	Werkzeug-Kabel	Câble D'Outil	Cable De la Herramienta	Cavo Dell'Attrezzo

(EN) \* Note: Contact (Cooper Power Tools)  
 (DE) \* Notiz: Kontakt (Cooper Power Tools)  
 (FR) \* Note: Contact (Cooper Power Tools)  
 (ES) \* Nota: Contato (Cooper Power Tools)  
 (IT) \* Nota: Contatto (Cooper Power Tools)

**TME-200 Series Controller**

Supply Voltage	EN	DE	PT	ES
	Order Number	Bestell-Nr.	Order Number	Referencia
115 VAC	TME-211-15-U	TME-211-15-D	TME-211-15-P	TME-211-15-S
115 VAC	TME-221-15-U	TME-221-15-D	TME-221-15-P	TME-221-15-S
230 VAC	TME-211-30-U	TME-211-30-D	TME-211-30-P	TME-211-30-S
230 VAC	TME-221-30-U	TME-221-30-D	TME-221-30-P	TME-221-30-S

“C1”

Models:

18EA16

18EA23

18EA30

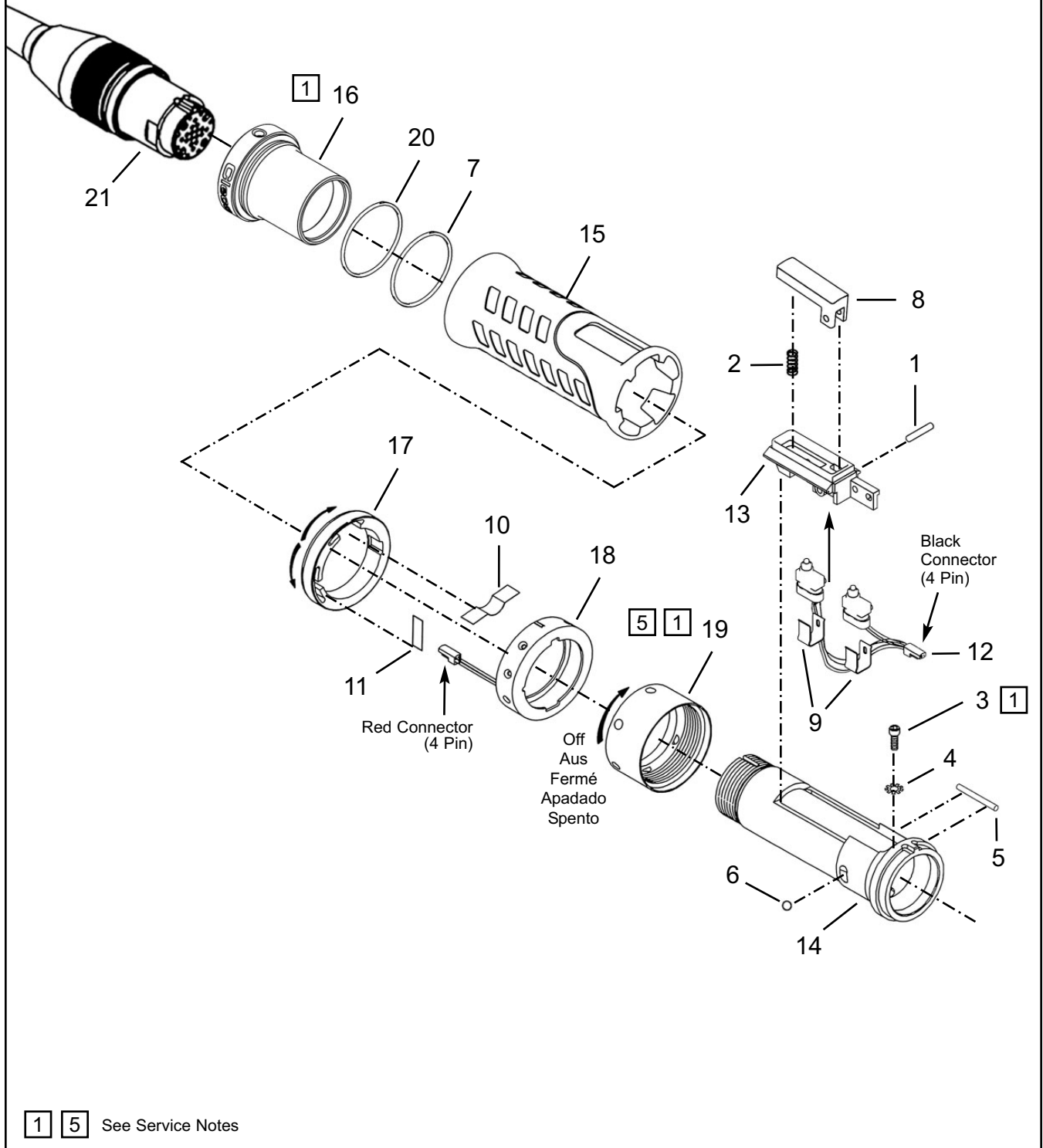

## Handle - Matrix Tool Connector

## Illustration, Abbildung, Illustration, Ilustración, Illustrazione "C1"

Ref	Number	#	X	EN	DE	FR	ES	IT
				Description	Benennung	Designation	Descripción	Descrizione
1	541480	1	3	Pin	Stift	Goupille cylindrique	Pasador	Spina
2	266255	1	3	Switch Spring	Druckfeder	Ressort	Resorte	Molla
3	B159V	1	3	Cap Screw #6-32	Schraube	Vis	Tornillo	Vite
4	W115	1	3	Lock Washer	Scheibe	Rondelle	Arandela	Rondella
5	1009089	1	3	Pin	Stift	Goupille cylindrique	Pasador	Spina
6	1091	1	3	Steel Ball, 3/16"	Stahlkugel	Bloom d'acier	Bola de acero	Sfera in acciaio
7	22598	1	3	O-Ring	O-Ring	Joint torique	Anillo "O"	Anello ad O
8	F900185	1		Switch Actuator	Hebel	Lever	Palanca	Leva
9	207317	2	2	Switch Spring Clip	Klipp	Agrafe	Presilla	Graffa
10	541033	1	2	Reverse Spring	Druckfeder	Ressort	Resorte	Molla
11	541624	1	2	Fwd/Rev Spring	Druckfeder	Ressort	Resorte	Molla
12	F900571	1	2	Start/Rev Switch	Schalter	Interrupteur	Interruptor	Interruttore
13	207316	1		Switch Holder	Schaltergehäuse	Anneau de fixation	Anillo de retención	Anello di fissaggio
14	541015	1		Handle	Handgriff	Poignée	Manija	Impugnatura
15	207323	1		Handle Sleeve	Hülse	Douille	Manguito	Manicotto
16	207325	1		Connector Sleeve	Hülse	Douille	Manguito	Manicotto
17	542938	1		Reverse Ring	Umschaltring	Anneau de renversement	Anillo de inversión	Anello di reversibilità
18	542819	1		Light Ring Asm.	LED-Ring kpl.	Bague	Anillo	Anello
19	541017	1		Handle Ret. Nut	Gewinding	Ecrou de retenue	Tuerca de retención	Dado di fissaggio
20	524818	1	3	O-Ring	O-Ring	Joint torique	Anillo "O"	Anello ad O
<b>Tool Cable (Optional Length)</b>								
21	542778-1M	1		1 meter cable	Kabel	Câble	Cable	Cavo
	542778-2M			2 meter cable	Kabel	Câble	Cable	Cavo
	542778-3M			3 meter cable	Kabel	Câble	Cable	Cavo
	542778-6M			6 meter cable	Kabel	Câble	Cable	Cavo
	542778-8M			8 meter cable	Kabel	Câble	Cable	Cavo
	542778-10M			10 meter cable	Kabel	Câble	Cable	Cavo
	542778-15M			15 meter cable	Kabel	Câble	Cable	Cavo
	542778-50M			50 meter cable	Kabel	Câble	Cable	Cavo
<b>Inline Swivel Cable (Optional Length)</b>								
21	544056-1M	1		1 meter cable	Kabel	Câble	Cable	Cavo
	544056-2M			2 meter cable	Kabel	Câble	Cable	Cavo
	544056-3M			3 meter cable	Kabel	Câble	Cable	Cavo
	544056-6M			6 meter cable	Kabel	Câble	Cable	Cavo
	544056-8M			8 meter cable	Kabel	Câble	Cable	Cavo
	544056-10M			10 meter cable	Kabel	Câble	Cable	Cavo
	544056-15M			15 meter cable	Kabel	Câble	Cable	Cavo
<b>Angle Swivel Cable (Optional Length)</b>								
21	544055-1M	1		1 meter cable	Kabel	Câble	Cable	Cavo
	544055-2M			2 meter cable	Kabel	Câble	Cable	Cavo
	544055-3M			3 meter cable	Kabel	Câble	Cable	Cavo
	544055-6M			6 meter cable	Kabel	Câble	Cable	Cavo
	544055-8M			8 meter cable	Kabel	Câble	Cable	Cavo
	544055-10M			10 meter cable	Kabel	Câble	Cable	Cavo
	544055-15M			15 meter cable	Kabel	Câble	Cable	Cavo
<b>Tool Cable Extention (Optional Length)</b>								
21	542779-1M	1		1 meter cable	Kabel	Câble	Cable	Cavo
	542779-2M			2 meter cable	Kabel	Câble	Cable	Cavo
	542779-3M			3 meter cable	Kabel	Câble	Cable	Cavo
	542779-6M			6 meter cable	Kabel	Câble	Cable	Cavo
	542779-10M			10 meter cable	Kabel	Câble	Cable	Cavo
	542779-15M			15 meter cable	Kabel	Câble	Cable	Cavo
	542779-50M			50 meter cable	Kabel	Câble	Cable	Cavo

(#) Quantity / Stückzahl / Quantité / Cantidad / Quantità

(X) Recommended Spare Parts / Kennzeichnet empfohlenes / Identifica un particolare di ricambio raccomandato / Designa el repuesto recomendado / Indique la pièce de rechange conseillée.

“C2”

Models:

18EAE16

18EAE23

18EAE30

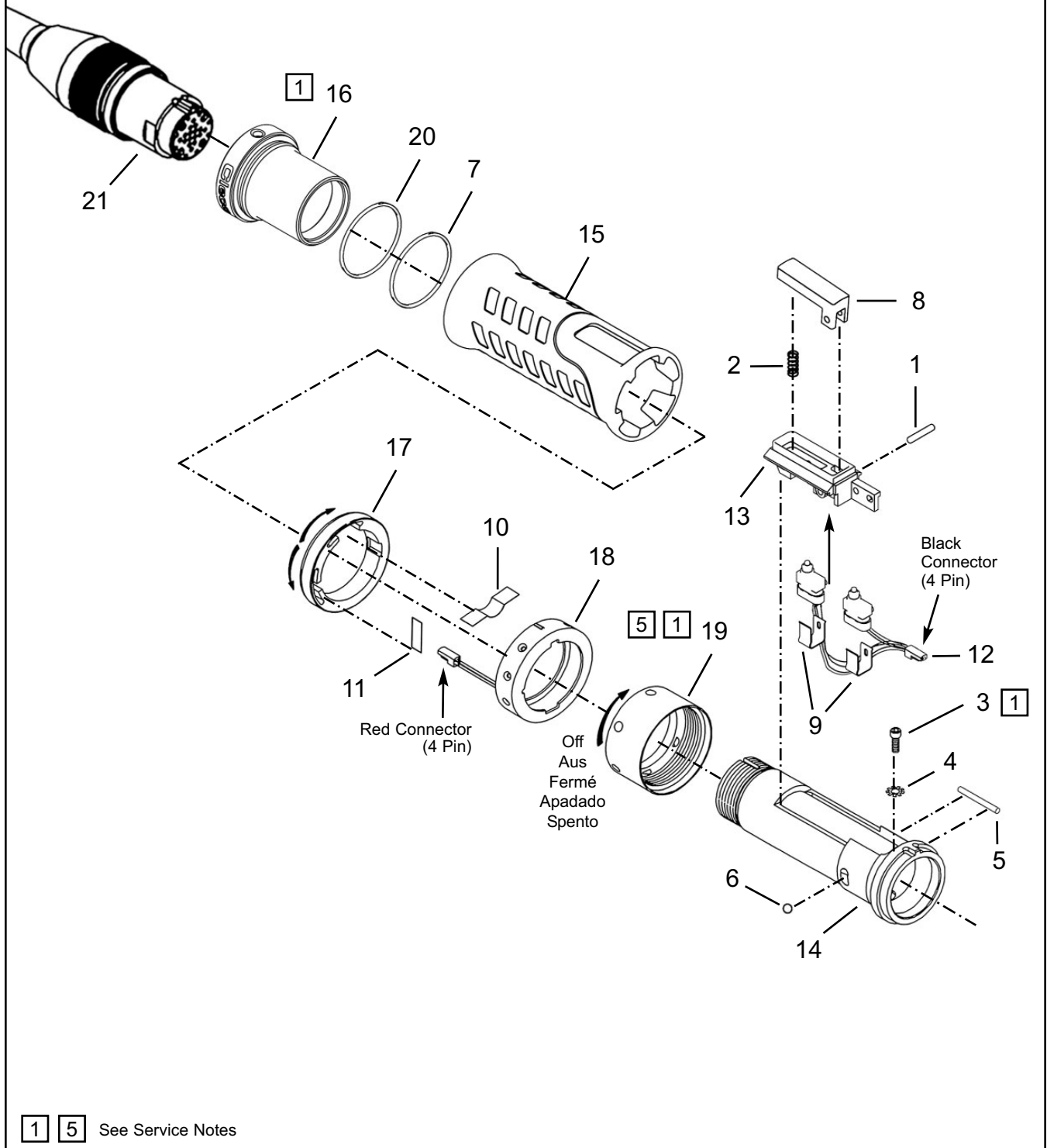

## Handle - Air LB Connector

## Illustration, Abbildung, Illustration, Ilustración, Illustrazione "C2"

Ref	Number	#	X	EN	DE	FR	ES	IT
				Description	Benennung	Designation	Descripción	Descrizione
1	541480	1	3	Pin	Stift	Goupille cylindrique	Pasador	Spina
2	266255	1	3	Switch Spring	Druckfeder	Ressort	Resorte	Molla
3	B159V	1	3	Cap Screw #6-32	Schraube	Vis	Tornillo	Vite
4	W115	1	3	Lock Washer	Scheibe	Rondelle	Arandela	Rondella
5	1009089	1	3	Pin	Stift	Goupille cylindrique	Pasador	Spina
6	1091	1	3	Steel Ball, 3/16"	Stahlkugel	Bloom d'acier	Bola de acero	Sfera in acciaio
7	22598	1	3	O-Ring	O-Ring	Joint torique	Anillo "O"	Anello ad O
8	F900185	1		Switch Actuator	Hebel	Lever	Palanca	Leva
9	207317	2	2	Switch Spring Clip	Klipp	Agrafe	Presilla	Graffa
10	541033	1	2	Reverse Spring	Druckfeder	Ressort	Resorte	Molla
11	541624	1	2	Fwd/Rev Spring	Druckfeder	Ressort	Resorte	Molla
12	F900571	1	2	Start/Rev Switch	Schalter	Interrupteur	Interruptor	Interruttore
13	207316	1		Switch Holder	Schaltergehäuse	Anneau de fixation	Anillo de retención	Anello di fissaggio
14	207322	1		Handle	Handgriff	Poignée	Manija	Impugnatura
15	207323	1		Handle Sleeve	Hülse	Douille	Manguito	Manicotto
16	207325E	1		Connector Sleeve	Hülse	Douille	Manguito	Manicotto
17	542938	1		Reverse Ring	Umschaltring	Anneau de renversement	Anillo de inversión	Anello di reversibilità
18	542819	1		Light Ring Asm.	LED-Ring kpl.	Bague	Anillo	Anello
19	541017	1		Handle Ret. Nut	Gewinding	Ecrou de retenue	Tuerca de retención	Dado di fissaggio
20	524818	1	3	O-Ring	O-Ring	Joint torique	Anillo "O"	Anello ad O
<b>Tool Cable (Optional Length)</b>								
21	961250-020	1		02 meter cable	Kabel	Câble	Cable	Cavo
	961250-030			03 meter cable	Kabel	Câble	Cable	Cavo
	961250-040			04 meter cable	Kabel	Câble	Cable	Cavo
	961250-060			06 meter cable	Kabel	Câble	Cable	Cavo
	961250-080			08 meter cable	Kabel	Câble	Cable	Cavo
	961250-100			10 meter cable	Kabel	Câble	Cable	Cavo
	961250-150			15 meter cable	Kabel	Câble	Cable	Cavo
<b>Inline Swivel Cable (Optional Length)</b>								
21	961251-020	1		02 meter cable	Kabel	Câble	Cable	Cavo
	961251-040			04 meter cable	Kabel	Câble	Cable	Cavo
	961251-080			08 meter cable	Kabel	Câble	Cable	Cavo
	961251-015			15 meter cable	Kabel	Câble	Cable	Cavo
<b>Angle Swivel Cable (Optional Length)</b>								
21	961252-020	1		02 meter cable	Kabel	Câble	Cable	Cavo
	961252-040			04 meter cable	Kabel	Câble	Cable	Cavo
	961252-080			08 meter cable	Kabel	Câble	Cable	Cavo
	961252-150			15 meter cable	Kabel	Câble	Cable	Cavo
<b>Tool Cable Extension (Optional Length)</b>								
21	960430-005	1		05 meter cable	Kabel	Câble	Cable	Cavo
	960430-008			08 meter cable	Kabel	Câble	Cable	Cavo
	960430-010			10 meter cable	Kabel	Câble	Cable	Cavo
	960430-020			20 meter cable	Kabel	Câble	Cable	Cavo
	960430-030			30 meter cable	Kabel	Câble	Cable	Cavo
	960430-040			40 meter cable	Kabel	Câble	Cable	Cavo
	960430-050			50 meter cable	Kabel	Câble	Cable	Cavo

(#) Quantity / Stückzahl / Quantité / Cantidad / Quantità

(X) Recommended Spare Parts / Kennzeichnet empfohlenes / Identifica un particolare di ricambio raccomandato / Designa el repuesto recomendado / Indique la pièce de rechange conseillée.

Motor - Matrix Tool Connector

Models:

18EA16

18EA23

18EA30

“D1”

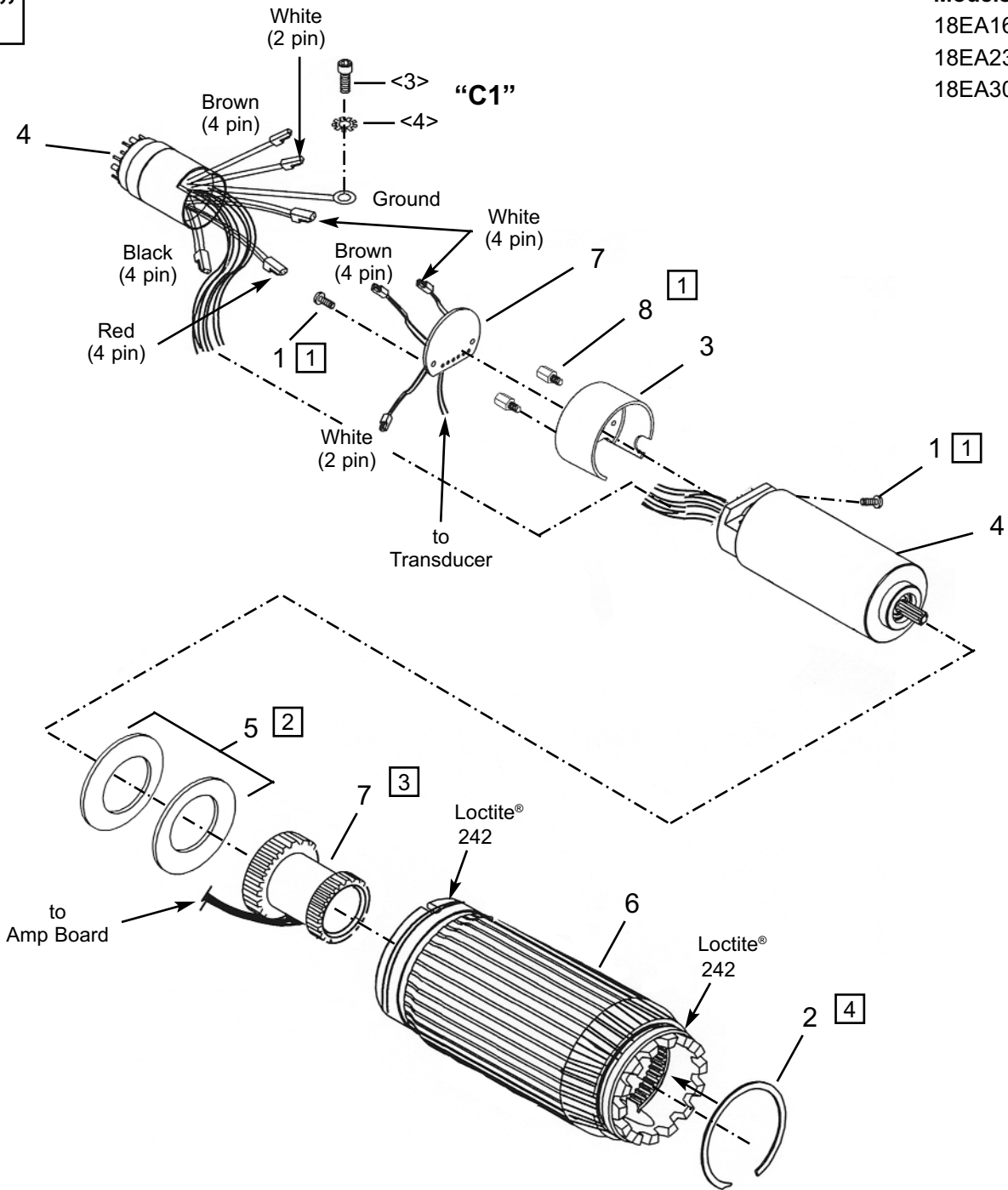

1 2 3 4 See Service Notes



## Motor - Matrix Tool Connector

## Illustration, Abbildung, Illustration, Ilustración, Illustrazione "D1"

Ref	Number	#	X	EN	DE	FR	ES	IT
				Description	Benennung	Designation	Descripción	Descrizione
1	17-111	3	6	Screw /#4-40 Pan Head	Schraube	Vis	Tornillo	Vite
2	505306	1	2	Retaining Ring	Sicherungsring	Anneau de fixation	Anillo de retención	Anello di fissaggio
3	542588	1		Motor Spacer	Distanzstück	Entretoise	Espaciador	Distanziale
4	301760	1		Motor Assembly	Motorbaugruppe	Ensemble du moteur	Ensamblaje del motor	Gruppo motore
5	541009	2	2	Wave Washer	Wellenscheibe	Rondelle ondulée	Arandela ondulada	Rondella ondulata
6	207339	1		Housing	Gehäuse	Corps	Caja	Corpo
7	Table "D1"	1		Transducer Asm.	Transducer	Transducteur	Transductor	Trasduttore
8	542244	2	2	Stand Off (5/16")	Distanzstück	Séparateur	Separador	Neutralizzatore

(#) Quantity / Stückzahl / Quantité / Cantidad / Quantità

(X) Recommended Spare Parts / Kennzeichnet empfohlenes / Identifica un particolare di ricambio raccomandato / Designa el repuesto recomendado / Indique la pièce de rechange conseillée.

## Table, Tabelle, Tableau, Tabla, Tabella "D1"

Ref.	Description	#	18EA16	#	18EA23	#	18EA30
7	Transducer (Unprogrammed)	1	542846-12	1	542846-17	1	542846-31
	Transducer (Programmed)	1	542846-12P	1	542846-17P	1	542846-31P
	Capacity		12Nm		17Nm		31Nm

Motor - Air LB Connector

“D2”

Models:  
18EAE16  
18EAE23  
18EAE30

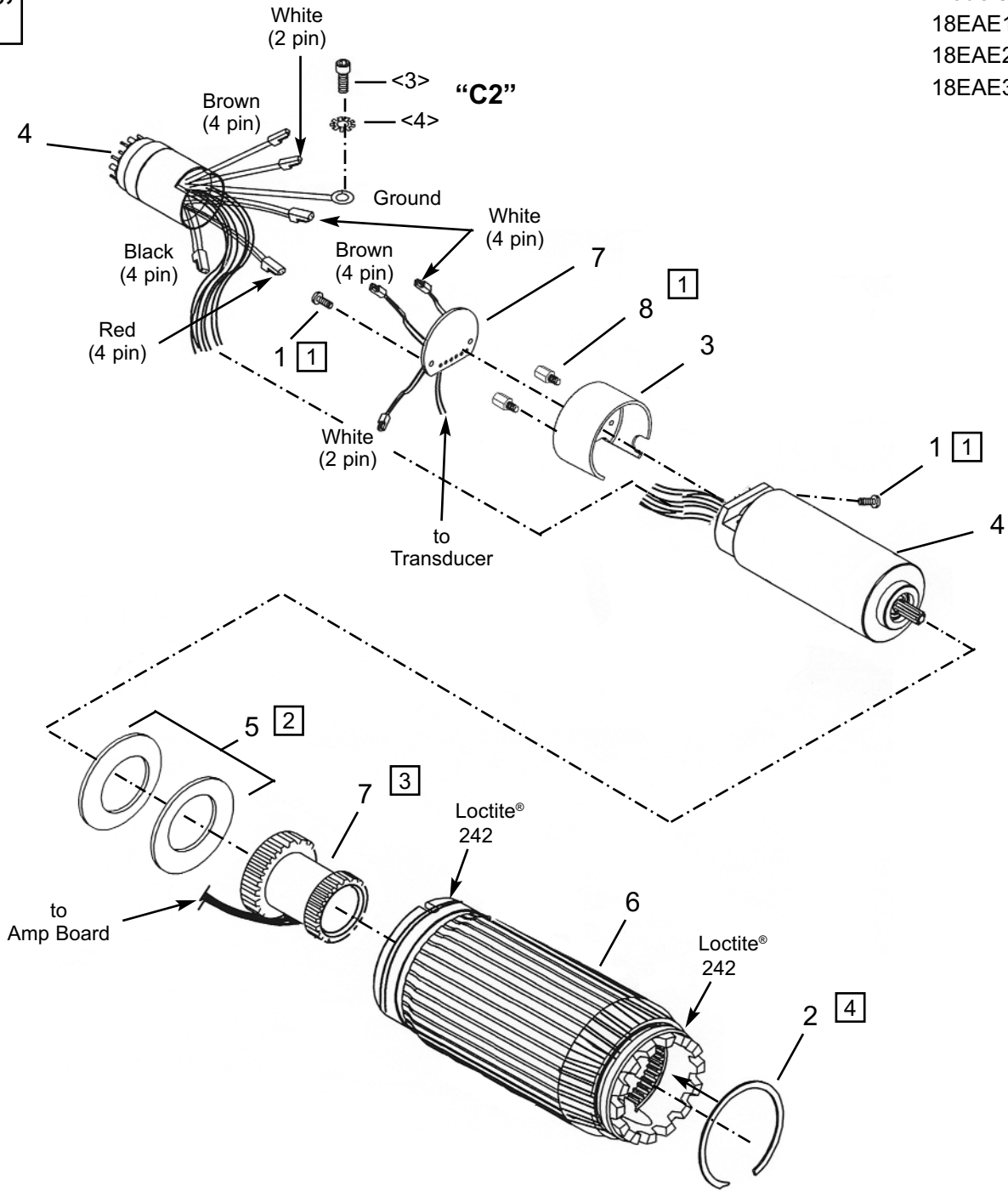

1 2 3 4 See Service Notes

## Motor - Air LB Connector

## Illustration, Abbildung, Illustration, Ilustración, Illustrazione "D2"

Ref	Number	#	X	EN	DE	FR	ES	IT
				Description	Benennung	Designation	Descripción	Descrizione
1	17-111	3	6	Screw /#4-40 Pan Head	Schraube	Vis	Tornillo	Vite
2	505306	1	2	Retaining Ring	Sicherungsring	Anneau de fixation	Anillo de retención	Anello di fissaggio
3	542588	1		Motor Spacer	Distanzstück	Entretoise	Espaciador	Distanziale
4	301760E	1		Motor Assembly	Motorbaugruppe	Ensemble du moteur	Ensamblaje del motor	Gruppo motore
5	541009	2	2	Wave Washer	Wellenscheibe	Rondelle ondulée	Arandela ondulada	Rondella ondulata
6	207339	1		Housing	Gehäuse	Corps	Caja	Corpo
7	Table "D2"	1		Transducer Asm.	Transducer	Transducteur	Transductor	Trasduttore
8	542244	2	2	Stand Off (5/16")	Distanzstück	Séparateur	Separador	Neutralizzatore

(#) Quantity / Stückzahl / Quantité / Cantidad / Quantità

(X) Recommended Spare Parts / Kennzeichnet empfohlenes / Identifica un particolare di ricambio raccomandato / Designa el repuesto recomendado / Indique la pièce de rechange conseillée.

## Table, Tabelle, Tableau, Tabla, Tabella "D2"

Ref.	Description	#	18EAE16	#	18EAE23	#	18EAE30
7	Transducer (Unprogrammed)	1	542846-12	1	542846-17	1	542846-31
	Transducer (Programmed)	1	542846-12P	1	542846-17P	1	542846-31P
	Capacity		12Nm		17Nm		31Nm

Double Stage Gearing

“E”

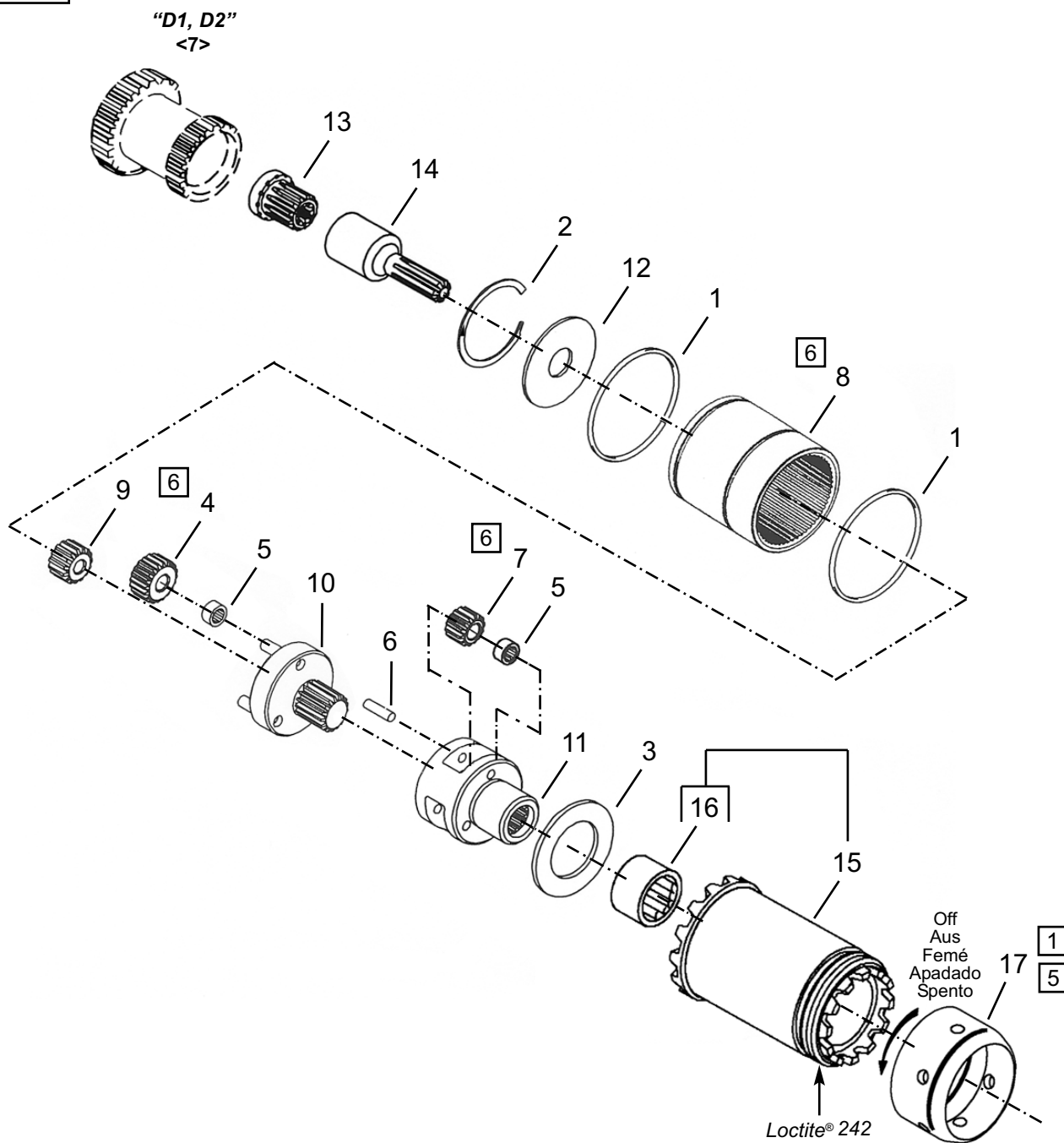

1 5 6 See Service Notes

## Double Stage Gearing

## Illustration, Abbildung, Illustration, Ilustración, Illustrazione "E"

Ref	Number	#	X	EN	DE	FR	ES	IT
				Description	Benennung	Designation	Descripción	Descrizione
1	542724	2	6	O-Ring	O-Ring	Joint torique	Anillo "O"	Anello ad O
2	800116	1	2	Retaining Ring	Sicherungsring	Anneau de fixation	Anillo de retención	Anello di fissaggio
3	502983	1	2	Thrust Washer	Druckscheibe	Rondelle de butée	Arandela de empuje	Rondella di spinta
4	Table "E"	3	6	Planet Gear	Planetengetriebe	Pignon satellite	Piñon satélite	Ingranaggio satellite
5	541487	6	12	Needle Bearing	Nadellager	Roulement à aiguilles	Cojinete de agujas	Cuscinetto a rulli
6	541888	3	6	Planet Pin	Planetenradzapfen	Goujon à satellite	Pasador de piñon satélite	Spina planetario
7	Table "E"	3	6	Planet Gear	Planetengetriebe	Pignon satellite	Piñon satélite	Ingranaggio satellite
8	542722	1		Ring Gear	Zahnkreis	Couronne dentée	Engranaje de anillos	Guarnizione ingranaggio
9	Table "E"	1	3	Slip On Gear	Steckritzel	Pignon coulissant	Engranaje de deslizamiento	Ingranaggio slittante
10	Table "E"	1		Planet Carrier Asm.	Planetenradträgergehäuse	Assemblage de porte-planète	Ensamblaje de portador planetario	Gruppo portasatellite
11	Table "E"	1		Planet Carrier	Planetenraeger	Porte-planète	Portador planetario	Portasatellite
12	541887	1	2	Washer	Scheibe	Rondelle	Arandela	Rondella
13	541044	1	2	Pinion Adapter	Zwischenstück	Adaptateur	Adaptador	Adattatore
14	541898	1	2	Extension Pinion	Pinion	Pignon	Piñón	Il pignone
15	542829	1		Adapter	Zwischenstück	Adaptateur	Adaptador	Adattatore
16	500528	1	3	Needle Bearing	Nadellager	Roulement à aiguilles	Cojinete de agujas	Cuscinetto a rulli
17	541904	1		Front Nut	Mutter	Ecrou	Tuerca	Dado

(#) Quantity / Stückzahl / Quantité / Cantidad / Quantità

(X) Recommended Spare Parts / Kennzeichnet empfohlenes / Identifica un particolare di ricambio raccomandato / Designa el repuesto recomendado / Indique la pièce de rechange conseillée.

(T) Teeth / Zähne / Dents / Dientes / Dente

## Table, Tabelle, Tableau, Tabla, Tabella "E"

Ref.	Description	#	18EA(E)16	#	18EA(E)23	#	18EA(E)30
4	Planet Gear	3	541894 (17T)	3	541894 (17T)	3	541893 (21T)
7	Planet Gear	3	541894 (17T)	3	541897 (20T)	3	541894 (17T)
9	Slip On Gear	1	541899	1	541899		---
10	Planet Carrier Asm	1	542230	1	542233	1	542231
11	Planet Carrier Asm	1	542079	1	542099	1	542079

(T) Teeth / Zähne / Dents / Dientes / Dente

Flush Socket Angle Head (Code F1XXXX)

“F”

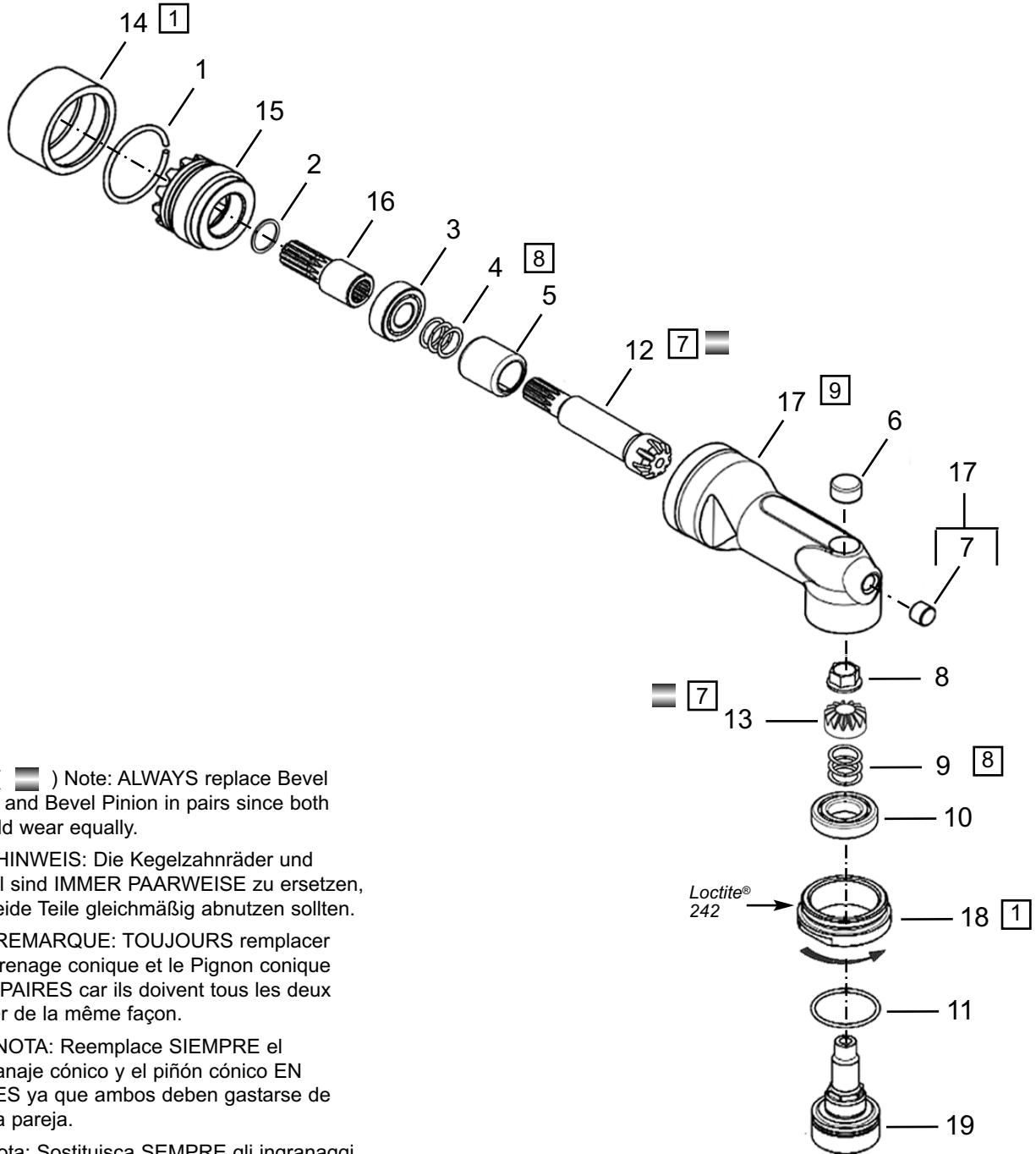





**EN:** (  ) Note: ALWAYS replace Bevel Gear and Bevel Pinion in pairs since both should wear equally.

**DE:** HINWEIS: Die Kegelzahnräder und Ritzel sind IMMER PAARWEISE zu ersetzen, da beide Teile gleichmäßig abnutzen sollten.

**FR:** REMARQUE: TOUJOURS remplacer l'Engrenage conique et le Pignon conique PAR PAIRES car ils doivent tous les deux s'user de la même façon.

**ES:** NOTA: Reemplace SIEMPRE el engranaje cónico y el piñón cónico EN PARES ya que ambos deben gastarse de forma pareja.

**IT:** Nota: Sostituiscia SEMPRE gli ingranaggi conici ed il pignone della smussatura negli accoppiamenti poiché entrambi dovrebbero portare ugualmente.

    See Service Notes

## Flush Socket Angle Head (Code F1XXXX)

## Illustration, Abbildung, Illustration, Ilustración, Illustrazione "F"

Ref	Number	Qty	X	EN	DE	FR	ES	IT
				Description	Benennung	Designation	Descripción	Descrizione
1	543115	1	3	Wire Ring Clip	Klipp	Agrafe	Presilla	Graffa
2	800146	1	3	Retaining Ring	Sicherungsring	Anneau de fixation	Anillo de retención	Anello di fissaggio
3	92100006	1	2	Ball Bearing	Kugellager	Roulement à billes	Cojinete de bolas	Cuscinetto a sfera
4	57019144	1	AR	Shim (.002")	Unterlegstück	Cale	Calzo	Spessore
	57019145	1	AR	Shim (.003")	Unterlegstück	Cale	Calzo	Spessore
	57019146	1	AR	Shim (.005")	Unterlegstück	Cale	Calzo	Spessore
5	92000024	1	2	Needle Bearing	Nadellager	Roulement à aiguilles	Cojinete de agujas	Cuscinetto a rulli
6	92010006	1	2	Needle Bearing	Nadellager	Roulement à aiguilles	Cojinete de agujas	Cuscinetto a rulli
7	12601432	1	2	Plug	Buchse	Bouchon	Tapón	Spina
8	93190025	1	1	Flanged Nut	Mutter	Ecrou	Tuerca	Dado
9	57019150	1	AR	Shim (.002")	Unterlegstück	Cale	Calzo	Spessore
	57019151	1	AR	Shim (.003")	Unterlegstück	Cale	Calzo	Spessore
	57019152	1	AR	Shim (.005")	Unterlegstück	Cale	Calzo	Spessore
10	92100092	1	2	Ball Bearing	Kugellager	Roulement à billes	Cojinete de bolas	Cuscinetto a sfera
11	93040022	1	3	O-Ring	O-Ring	Joint torique	Anillo "O"	Anello ad O
12	57017141	1	1	Pinion Gear	Ritzelgetriebe	Pignon d'entraînement	Piñon diferencial	Ingranaggio a pignone
13	57017142	1	1	Bevel Gear	Kegelrad	Engrenage conique	Engranaje cónico	Ingranaggio conico
14	543112	1		Lock Nut	Überwurfmutter	Contre-ecrou molette	Tuerca de fijación	Dado di bloccaggio
15	543114	1		Knotched Adapter	Zwischenstück	Adaptateur	Adaptador	Adattatore
16	543113	1	1	Drive Adapter	Zwischenstück	Adaptateur	Adaptador	Adattatore
17	57016138	1		Angle Housing	Winkelkopfgehäuse	Cage d'équerre	Alojamiento angular	Corpo testina angolare
18	57018166	1		Retainer Nut	Gewinding	Ecrou de retenue	Tuerca de retención	Dado di fissaggio
19	Table "F"	1		Output Spindle	Spindel	Arbre	Husillo	Mandrino

(#) Quantity / Stückzahl / Quantité / Cantidad / Quantità

(X) Recommended Spare Parts / Kennzeichnet empfohlenes / Identifica un particolare di ricambio raccomandato / Designa el repuesto recomendado / Indique la pièce de rechange conseillée.

## Table, Tabelle, Tableau, Tabla, Tabella "F"

18	E	A	E	XX	F1	XX	X	X
Tool Termination								
F1 = Flush Socket								
Drive Socket								
EB = 5/16"	MB = 8mm	XX = Special						
EE = 1/2"	MD = 10mm	00 = No Socket						
EF = 9/16"	ME = 11mm	01 = First Special						
	MF = 12mm	02 = Second Special						
	MG = 13mm	etc.						
	MH = 14mm							
	MI = 15mm							
Extension								
0 = Flush	6 = 3/4"							
2 = 1/4"	8 = 1"							
4 = 1/2"								
Output Type								
0 = Standard								
1 = Fast Lead								
2 = Magnetic								

**1**

Illustration Abbildung Illustration Ilustración Illustrazione	Reference Verweisung Référence Referencia Riferimento	Tightening torque Anzugsmoment Torsion de serrage Torsión de apriete Coppia di serraggio	
		Ft. Lbs. (In. Lbs.)	Nm
		C1	3
C2	16	25-30	34-41
	19	35-40	47-54
D1	1	(4-6)	0,45-0,68
D2	8	(4-6)	0,45-0,68
E	17	30-35	41-47
F	14	13-18	18-24
	18	35-40	47-54

**3 Illustrations "D1 & D2"**

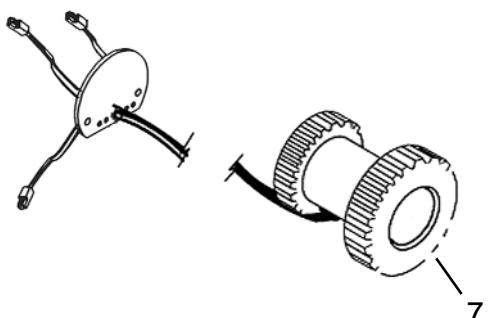

EN: Transducers are not interchangeable, check part number.  
 DE: Transducer sind nicht austauschbar, Kontrolle Teilnummer.  
 FR: Les transducteurs ne sont pas interchangeables, le numéro de partie de chèque.  
 ES: Los transductores no son intercambiables, el número de la parte de cheque.  
 IT: I trasduttori non sono intercambiabili, il numero di parte di assegno.

**2 Illustrations "D1 & D2"**

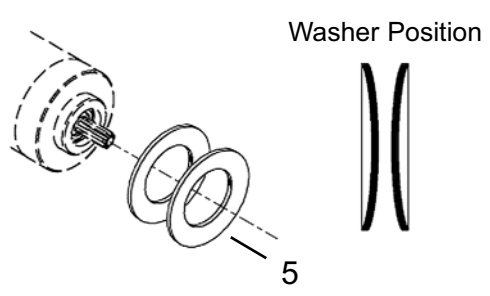

EN: Assembly of washers.  
 DE: Montage - Scheibe  
 FR: Assemblage - Rondelle  
 ES: Ensamblaje - Arandela  
 IT: Assemblaggio - Rondella

**4 Illustrations "D1, D2"**

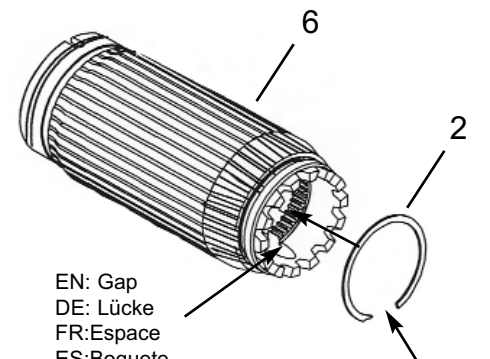

EN: Gap  
 DE: Lücke  
 FR: Espace  
 ES: Boquete  
 IT: Spacco

EN: Gap  
 DE: Öffnung  
 FR: ouverture  
 ES: abertura  
 IT: apertura



**5 Illustrations "C1, C2, E"**

EN: Spanner Wrench  
DE: Stellschlüssel  
FR: Clé de réglage  
ES: Llave ajustable  
IT: Chiave di regolazione

EN: Pin - 3/16"  
DE: Stift - 4.76mm  
FR: Goupille cylindrique - 4.76mm  
ES: Pasador - 4.76mm  
IT: Spina - 4.76mm

EN: Off  
DE: Aus  
FR: Fermé  
ES: Apagado  
IT: Spento

**7 Illustration "F"**

540394 - 2.8 oz. (79 g)

EN: Grease  
DE: Schmiermittel  
FR: Graisse  
ES: Grasa  
IT: Grasso

EN: Pinion Gears  
DE: Ritzelgetriebe  
FR: Pignon d'entraînement  
ES: Piñon diferencial  
IT: Ingranaggio a pignone

EN: Bevel Gears  
DE: Kegelrad  
FR: Engrenage conique  
ES: Engranaje cónico  
IT: Ingranaggio conico

TEFLON

GREASE

**6 Illustration "E"**

541444 - 2 oz. (56 g)  
541445 - 16 oz. (0.45 kg)

EN: Idler Gears  
DE: Zwischenzahnrad  
FR: Engrenage secondaire  
ES: Engranaje secundario  
IT: Ingranaggio intermedio

EN: Grease  
DE: Schmiermittel  
FR: Graisse  
ES: Grasa  
IT: Grasso

EN: Pinion Gears  
DE: Ritzelgetriebe  
FR: Pignon d'entraînement  
ES: Piñon diferencial  
IT: Ingranaggio a pignone

EN: Ring Gears  
DE: Zahnkreis  
FR: Couronne dentée  
ES: Engranaje de anillos  
IT: Guarnizione ingranaggio

**8 Illustration "F"**

(4 12)

EN: Shim to obtain dimension shown.  
DE: Benutzen Sie Distanzscheiben, um das gezeigte Maß zu erzielen  
FR: Employez les entretoises pour réaliser la dimension montrée  
ES: Utilice los espaciadores para alcanzar la dimensión demostrada  
IT: Usi i distanziatori per realizzare la dimensione indicata

(9 - 13)

EN: Run gears under load. Shim to obtain .002/.004 backlash.  
DE: Lassen Sie Zahnräder unter Last laufen. Messplättchen, zum von .051/.102 mm Abstand zu erhalten.  
FR: Courez les vitesses sous la charge. Cale pour obtenir .051/.102 mm d'espacement.  
ES: Funcione con los engranajes bajo carga. Cale pour obtenir .051/.102 mm d'espacement.  
IT: Faccia funzionare gli ingranaggi nell'ambito del carico. Cale pour obtenir .051/.102 mm d'espacement.

4 12 .258 .257 13 9

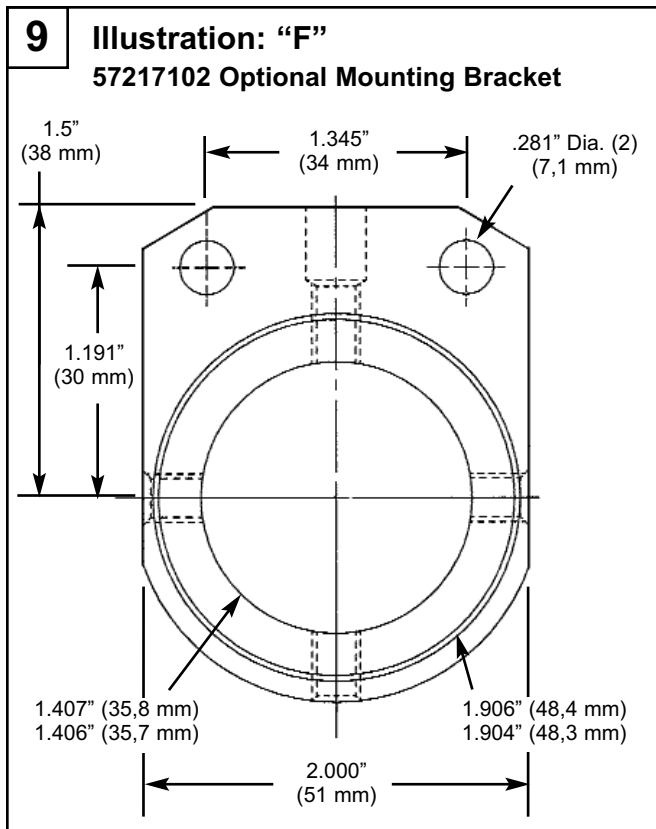

**Tool Memory Parameters**

<b>Model Number</b>	<b>Free Speed [RPM]</b>	<b>Max Torque [Nm]</b>	<b>Torque Cal [Nm]</b>	<b>Transducer Type</b>	<b>Angle Cal [PPD]</b>	<b>Static Current Factor [Nm/A]</b>
18EA(E)16Fxxx	1225	16	17.7541	542846-12	70.2893	1.5306
18EA(E)23Fxxx	860	23	24.6342	542846-17	99.1829	2.1598
18EA(E)30Fxxx	655	30	44.3960	542846-31	129.8824	2.8283

## Sales & Service Centers

**Note:** All locations may not service all products. Please contact the nearest Sales & Service Center for the appropriate facility to handle your service requirements.

Dallas, TX  
**Apex Tool Group  
Sales & Service Center**  
1470 Post & Paddock  
Grand Prairie, TX 75050  
Tel: 972-641-9563  
Fax: 972-641-9674

Detroit, MI  
**Apex Tool Group  
Sales & Service Center**  
2630 Superior Court  
Auburn Hills, MI 48326  
Tel: 248-391-3700  
Fax: 248-391-7824

Houston, TX  
**Apex Tool Group  
Sales & Service Center**  
6550 West Sam Houston  
Parkway North, Suite 200  
Houston, TX 77041  
Tel: 713-849-2364  
Fax: 713-849-2047

Lexington, SC  
**Apex Tool Group**  
670 Industrial Drive  
Lexington, SC 29072  
Tel: 800-845-5629  
Tel: 803-951-7544  
Fax: 803-358-7681

Los Angeles, CA  
**Apex Tool Group  
Sales & Service Center**  
15503 Blackburn Avenue  
Norwalk, CA 90650  
Tel: 562-623-4457  
Fax: 562-802-1718

Seattle, WA  
**Apex Tool Group  
Sales & Service Center**  
2865 152nd Avenue N.E.  
Redmond, WA 98052  
Tel: 425-497-0476  
Fax: 425-497-0496

York, PA  
**Apex Tool Group  
Sales & Service Center**  
3990 East Market Street  
York, PA 17402  
Tel: 717-755-2933  
Fax: 717-757-5063

Canada  
**Apex Tool Group  
Sales & Service Center**  
5925 McLaughlin Road  
Mississauga, Ont. L5R 1B8  
Canada  
Tel: 905-501-4785  
Fax: 905-501-4786

Germany  
Cooper Power Tools  
GmbH & Co. OHG  
a company of  
Apex Tool Group, LLC  
Industriestraße 1  
73463 Westhausen  
Germany  
Tel: +49 (0) 73 63 81 0  
Fax: +49 (0) 73 63 81 222

England  
Cooper Power Tools  
GmbH & Co. OHG  
a company of  
Apex Tool Group, LLC  
C/O Spline Gauges  
Piccadilly, Tamworth  
Staffordshire B78 2ER  
United Kingdom  
Tel: +44 1827 8741 28  
Fax: +44 1827 8741 28

France  
Cooper Power Tools SAS  
a company of  
Apex Tool Group, LLC  
25 rue Maurice Chevalier  
77330 Ozoir-La-Ferrière  
France  
Tel: +33 1 6443 2200  
Fax: +33 1 6443 1717

China  
Cooper (China) Co., Ltd.  
a company of  
Apex Tool Group, LLC  
955 Sheng Li Road,  
Heqing Pudong, Shanghai  
China 201201  
Tel: +86-21-28994176  
Fax: +86-21-51118446

Mexico  
Cooper Tools  
de México S.A. de C.V.  
a company of  
Apex Tool Group, LLC  
Vialidad El Pueblito #103  
Parque Industrial Querétaro  
Querétaro, QRO 76220  
Mexico  
Tel: +52 (442) 211-3800  
Fax: +52 (442) 103-0443

Brazil  
Cooper Tools Industrial Ltda.  
a company of  
Apex Tool Group, LLC  
Av. Liberdade, 4055  
Zona Industrial - Iporanga  
SP Brazil  
Tel: +55 15 2383929  
Fax: +55 15 2383260

Hungary  
Cooper Tools Hungaria Kft.  
a company of  
Apex Tool Group, LLC  
Berkenyefa sor 7  
Pf: 640  
9027 Győr  
Hungary  
Tel: +36 96 66 1383  
Fax: +36 96 66 1135

Apex Tool Group, LLC  
1000 Lufkin Road  
Apex, NC 27539  
Phone: 919-387-0099  
Fax: 919-387-2614  
www.apextoolgroup.com

# Cleco®